

# Heller

# AHN2

# FRENCH TRUCK

## 30324



## Français

Renault a commencé à développer la série AH de camions pour l'armée française en 1939. L'un de ces camions moyens de la classe des 3 tonnes est l'AHN, avec une charge utile de 3,5 tonnes.

Le prototype est présenté en février 1940. Sa conception est assez simple, avec une cabine plate sans capot. Il est équipé d'un moteur 6 cylindres et d'une propulsion arrière. La production en série débute en mars 1941 à Boulogne-Billancourt, spécifiquement pour la Wehrmacht allemande et sous la direction de l'administration d'occupation allemande. De nombreux camions AHN ont été utilisés par toutes les armées allemandes jusqu'à la fin de la guerre, aussi bien sur le front germano-soviétique, qu'en Italie et en France. Après la libération de l'usine par les Alliés en 1944, la production de camions a repris. Environ 4 000 camions AHN ont été produits entre 1941 et 1944. Une version modifiée du camion, le AHN2, a ensuite été produite en série.

Utilisé pour les besoins militaires de la France il est également vendu à des fins civiles. La production a duré de novembre 1944 à juin 1946, puis jusqu'en 1947 pour les véhicules civils.

Au total, 8 400 exemplaires ont été livrés.

## English

Renault began developing the AH series of trucks for the French army in 1939. One of these medium trucks in the 3-tonne class was the AHN, with a payload of 3.5 tons.

The prototype was presented in February 1940. Its design was quite simple, with a flat cab without a bonnet. It had a 6-cylinder engine and rear-wheel drive. Series production began in March 1941 at Boulogne-Billancourt, specifically for the German Wehrmacht and under the direction of the German occupation administration.

Many AHN trucks were used by all the German armies until the end of the war, on the German-Soviet front as well as in Italy and France.

After the liberation of the plant by the Allies in 1944, truck production was resumed. About 4000 AHN trucks were produced between 1941 and 1944.

A modified version of the truck, the AHN2, then went into series production.

Used for France's military needs, it was also sold for civilian use. Production lasted from November 1944 to June 1946, then for civilian vehicles until 1947.

A total of 8,400 were delivered.

## Deutsch

Die Firma Renault begann mit der Entwicklung von Lastkraftwagen der Baureihe AH für die französische Armee 1939. Einer dieser mittleren Lastkraftwagen der 3-Tonnen-Klasse, war der AHN mit einer Nutzlast von 3,5 Tonnen.

Der Prototyp wurde im Februar 1940 präsentiert. Sein Design war recht einfach, mit einem flachen Fahrerhaus ohne Motorhaube. Er verfügte über einen 6-Zylinder-Motor und einen Heckantrieb. Die Serienproduktion begann im März 1941, in Boulogne-Billancourt, speziell für die deutsche Wehrmacht und unter der Leitung der deutschen Besatzungsverwaltung.

Viele AHN-Lastwagen waren bis Kriegsende bei allen deutschen Armeen im Einsatz, sowohl an der deutsch-sowjetischen Front als auch in Italien und Frankreich.

Nach der Befreiung des Fahrzeug Werkes durch die Alliierten im Jahr 1944, wurde die LKW-Produktion wieder aufgenommen. In den Jahren 1941-1944 wurden etwa 4000 AHN-Lastwagen produziert.

Die Modifikation des LKW mit der Bezeichnung AHN2 ging anschließend in Serie. Er war für den militärischen Bedarf Frankreichs bestimmt, wurde aber auch für zivile Zwecke verkauft. Die Produktion dauerte von November 1944 bis Juni 1946, für Zivilfahrzeuge bis 1947.

Insgesamt wurden 8.400 Stück ausgeliefert.

## Español

Renault comenzó a desarrollar la serie AH de camiones para el ejército francés en 1939. Uno de estos camiones medianos de la clase de 3 toneladas es el AHN, con una carga útil de 3,5 toneladas.

El prototipo se presentó en febrero de 1940. Su diseño es bastante simple, con una cabina plana sin capó. Está equipado con un motor de 6 cilindros y propulsión trasera. La producción en serie comienza en marzo de 1941 en Boulogne-Billancourt, específicamente para la Wehrmacht alemana y bajo la dirección de la administración de las fuerzas de ocupación alemanas. Muchos camiones AHN fueron utilizados por todos los ejércitos alemanes hasta el final de la guerra, tanto en el frente germano-soviético como en Italia y Francia. Después de la liberación de la fábrica por los Aliados en 1944, se reanudó la producción de camiones. Se produjeron aproximadamente 4000 camiones AHN entre 1941 y 1944. Posteriormente, se produjo en serie una versión modificada del camión, el AHN2.

Utilizado para las necesidades militares de Francia, también se vende para fines civiles. La producción duró desde noviembre de 1944 hasta junio de 1946, y luego continuó hasta 1947 para los vehículos civiles.

En total se han entregado 8 400 ejemplares.

## Italiano

Renault ha iniziato a sviluppare la serie AH di camion per l'esercito francese nel 1939. Uno di questi camion medi della classe da 3 tonnellate è l'AHN, con carico massimo di 3,5 tonnellate.

Il prototipo è stato presentato nel febbraio 1940. La sua concezione è abbastanza semplice, con cabina piatta senza cofano. Era dotato di un motore a 6 cilindri e di propulsione posteriore. La produzione in serie è iniziata nel marzo 1941 a Boulogne-Billancourt, specificamente per la Wehrmacht tedesca e sotto la direzione dell'amministrazione di occupazione tedesca. Le armate tedesche ne hanno usati tantissimi fino alla fine della guerra,

sia sul fronte tedesco-sovietico, sia in Italia e Francia. La produzione di questi autocarri è stata ripresa dopo la liberazione della fabbrica da parte degli Alleati, nel 1944. Tra il 1941 e il 1944 ne sono stati prodotti circa 4.000 esemplari. Successivamente è stata avviata la produzione in serie di una versione modificata, l'AHN2.

Utilizzato per le esigenze militari francesi, è stato venduto anche per scopi civili. La produzione è durata dal novembre 1944 al giugno 1946 e fino al 1947 per i veicoli civili.

In totale ne sono stati consegnati 8.400 esemplari.

## Nederlands

Renault begon in 1939 met de ontwikkeling van de AH-serie trucks voor het Franse leger. Een van deze middelzware trucks in de 3-tons klasse is het AHN, met een laadvermogen van 3,5 ton.

Het prototype werd gepresenteerd in februari 1940. Het ontwerp is vrij eenvoudig, met een platte cabine en zonder motorkap. Hij heeft een 6-cilinder motor en achterwielaandrijving. De massaproductie begon in Boulogne-Billancourt in maart 1941, specifiek voor de Duitse Wehrmacht en onder leiding van de administratie van de Duitse bezetter. Veel AHN trucks werden gebruikt door alle Duitse legers tot het einde van de oorlog, zowel aan het Duits-Sovjet front als in Italië en Frankrijk. Nadat de fabriek in 1944 werd bevrijd door de geallieerden, werd de vrachtwagenproductie hervat. Tussen 1941 en 1944 werden ongeveer 4.000 AHN-trucks geproduceerd. Een aangepaste versie van de truck, de AHN2, werd vervolgens in massa geproduceerd.

Het wordt gebruikt voor de militaire behoeften van Frankrijk, maar wordt ook verkocht voor civiel gebruik. De productie duurde van november 1944 tot juni 1946, daarna tot 1947 voor civiele voertuigen.

Er werden in totaal 8.400 exemplaren geleverd.

1/35

## AHN2 FRENCH TRUCK

30324



11  
Argent métallique  
Silver Metallic  
Silber metallisch



19  
Rouge vif brillant  
Bright Red Gloss  
Hellrot glänzend



34  
Blanc mat  
White Matt  
Weiß matt



53  
Gris métallique  
Gunmetal Metallic  
Grau metallisch



56  
Aluminium métallique  
Aluminium Metallic  
Aluminium metallisch



85  
Noir de charbon satiné  
Coal Black Satin  
Kohlenschwarz seidenmatt



86  
Olive clair mat  
Light Olive Matt  
Olivgrün hell matt



92  
Gris fer mat  
Iron Grey Matt  
Eisengrau matt



93  
Jaune désert mat  
Desert Yellow Matt  
Wüstensand matt



113  
Rouille mat  
Rust Matt  
Rost matt

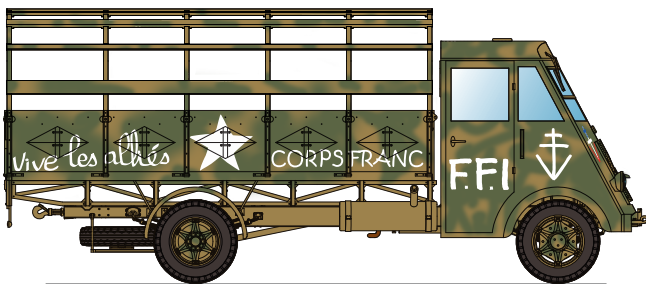

*a* AHN capturé par les FFI (Forces Françaises de l'Intérieur), évocation, France, août 1944.  
AHN captured by the FFI (Forces Françaises de l'Intérieur), evocative, France, August 1944.

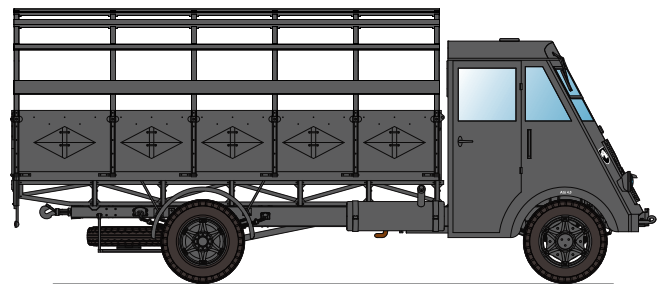

*b* Lastkraftwagen 3,5 t AHN, 336<sup>e</sup> Division d'Infanterie, Taganrog, URSS, Automne 1942.  
Lastkraftwagen 3,5 t AHN, 336th Infantry Division, Taganrog, USSR, Autumn 1942.

- Si aucune teinte n'est spécifiée, peindre dans les couleurs de la version choisie. Se reporter aux pages 18 - 19 pour le détail du schéma de peinture.
- When no color is specified, paint the item with colors of chosen version. Refer to pages 18 - 19 for painting pattern.
- Wenn keine Farbe angegeben ist, Teile mit den Farben der gewählten Version bemalen. Beachten Sie die Seiten 18 - 19 für die Lackierung und Markierung.
- Cuando ningún color es especificado, pintarle con los colores del tema de la versión elegida. Vea las páginas 18 - 19 para obtener detalles de pintura.

2

Numéro de phase  
Step number  
Schrittnummer  
Número de fase

56

Référence de couleur  
Colour reference no  
Farbangabe  
Referencia de color

37

Numéro de pièce  
Part number  
Teilenummer  
Número de pieza

6

Numéro de decal  
Decal number  
Abziehbildnummer  
Número de calcomanía

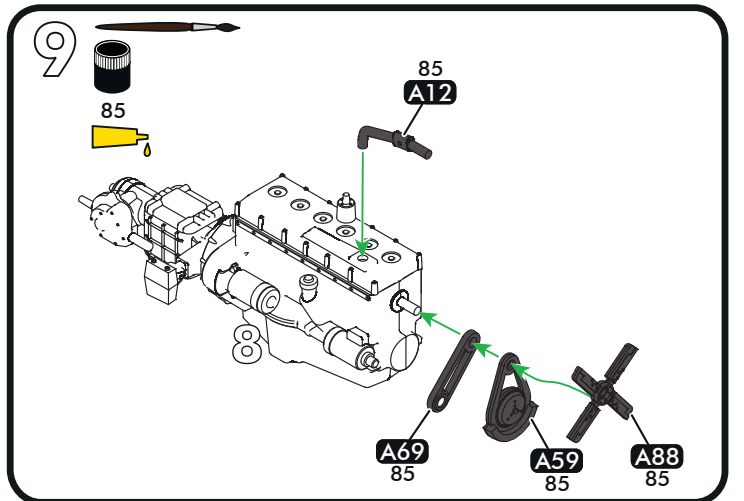
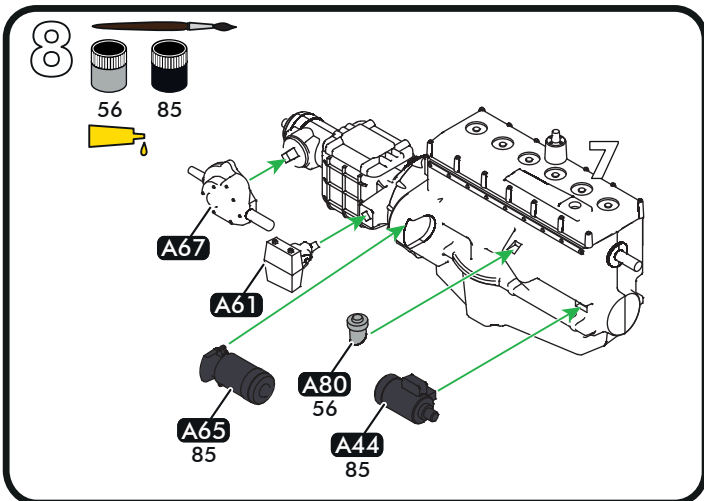
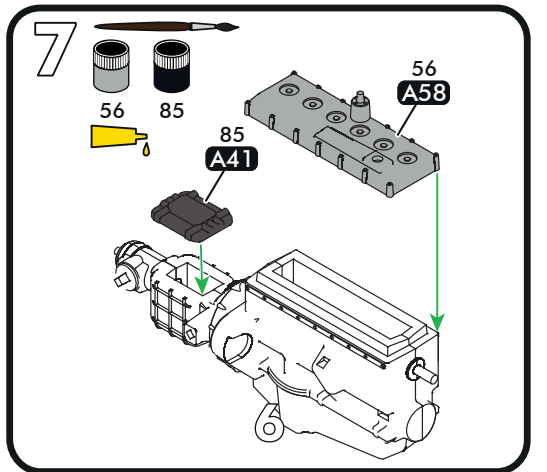
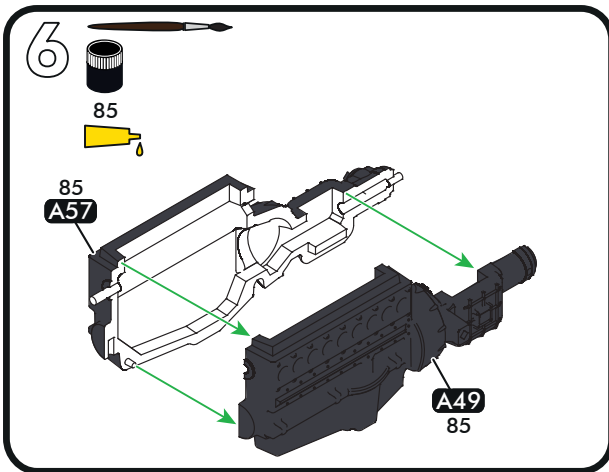
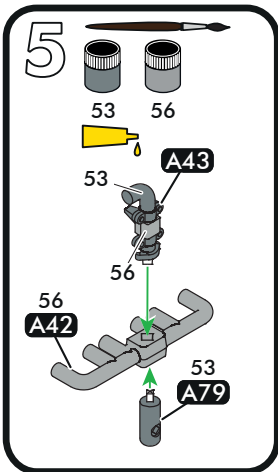
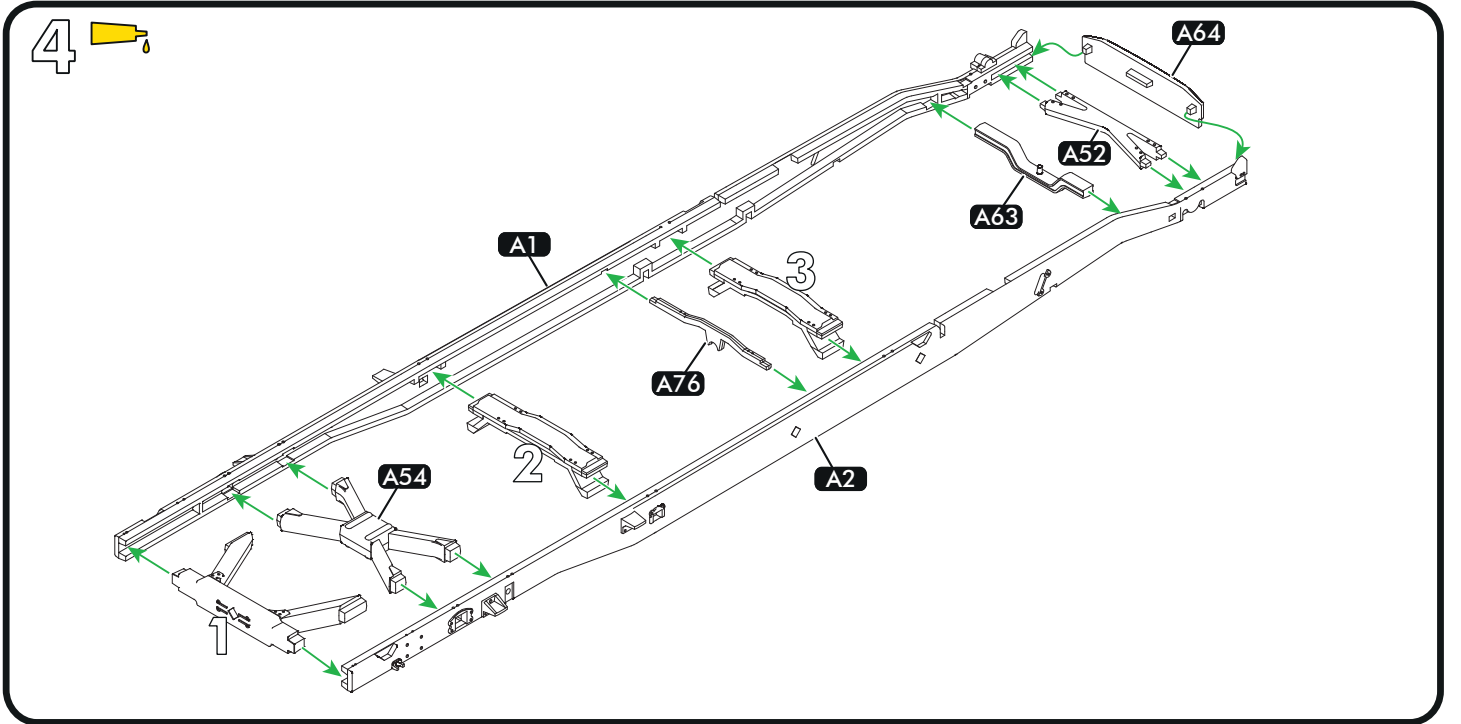
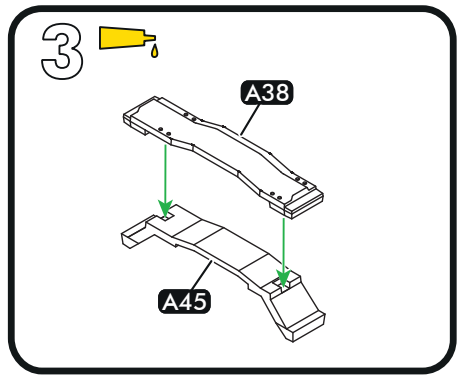
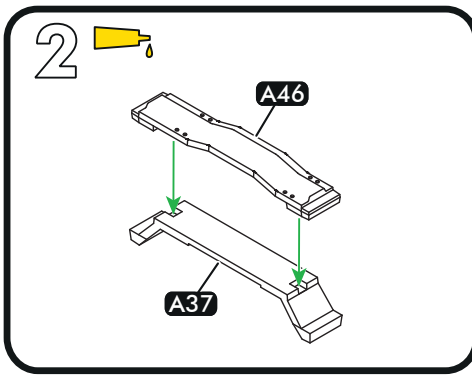
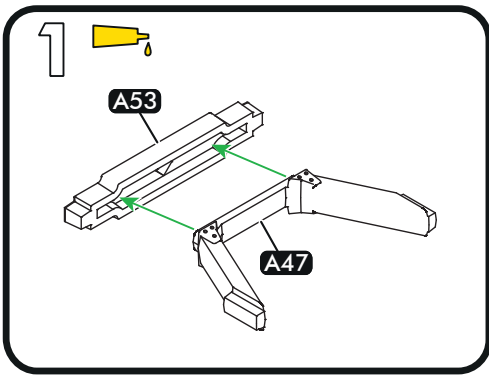

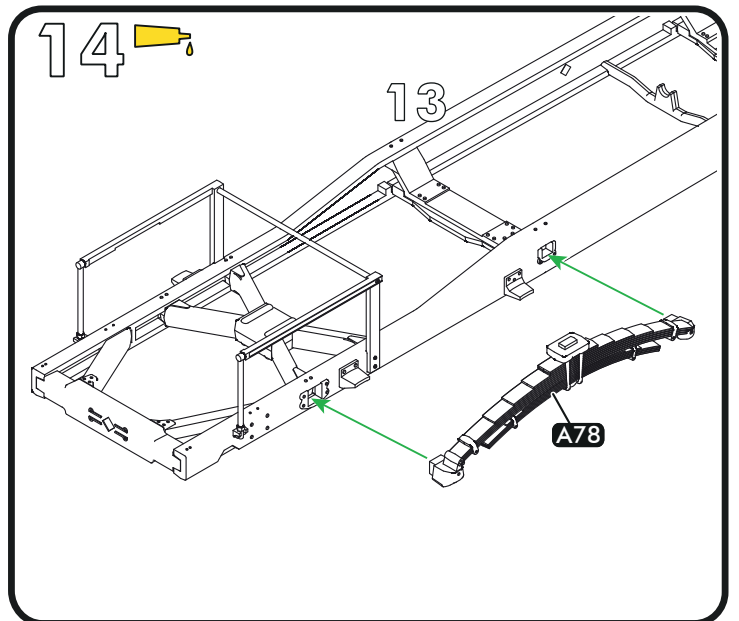
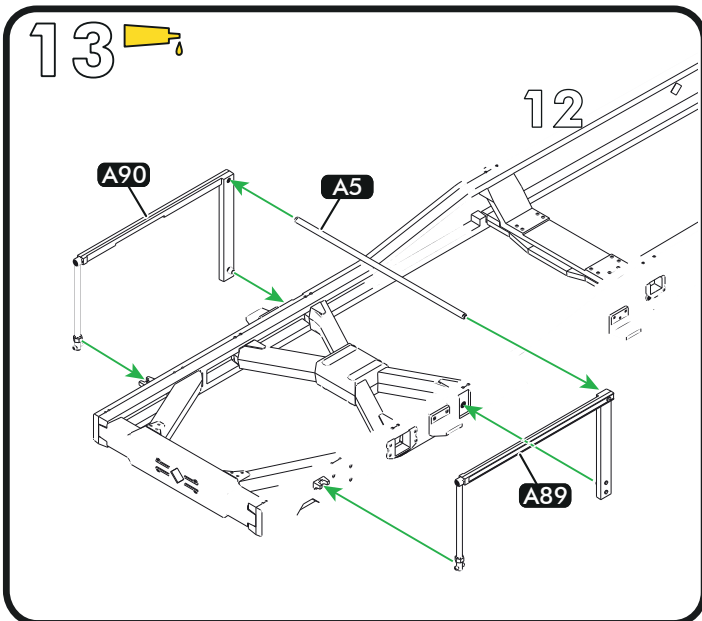
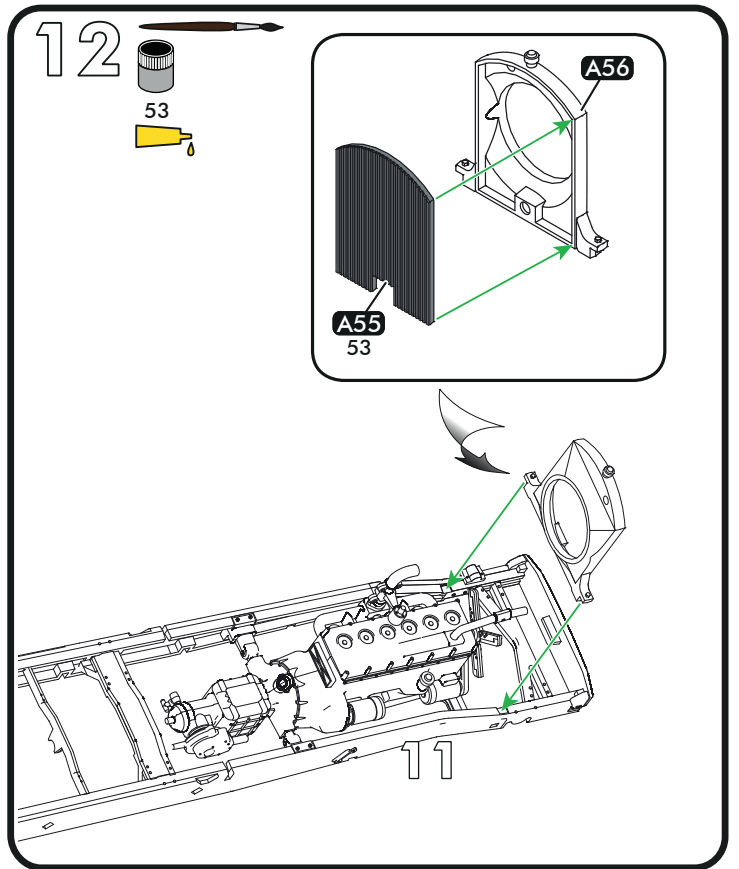
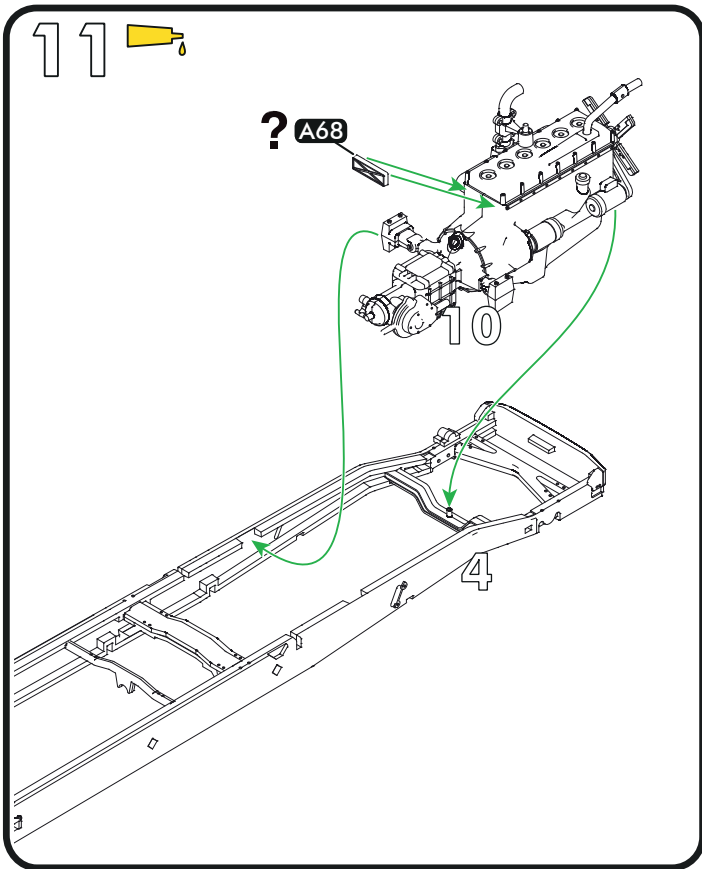
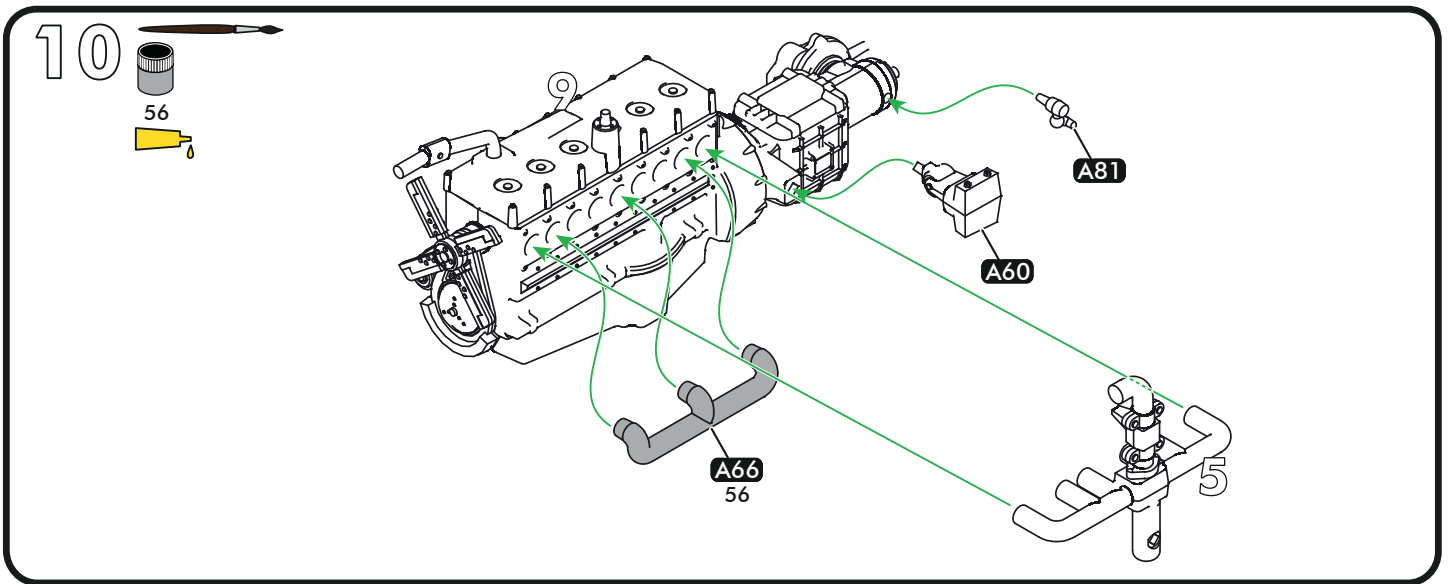

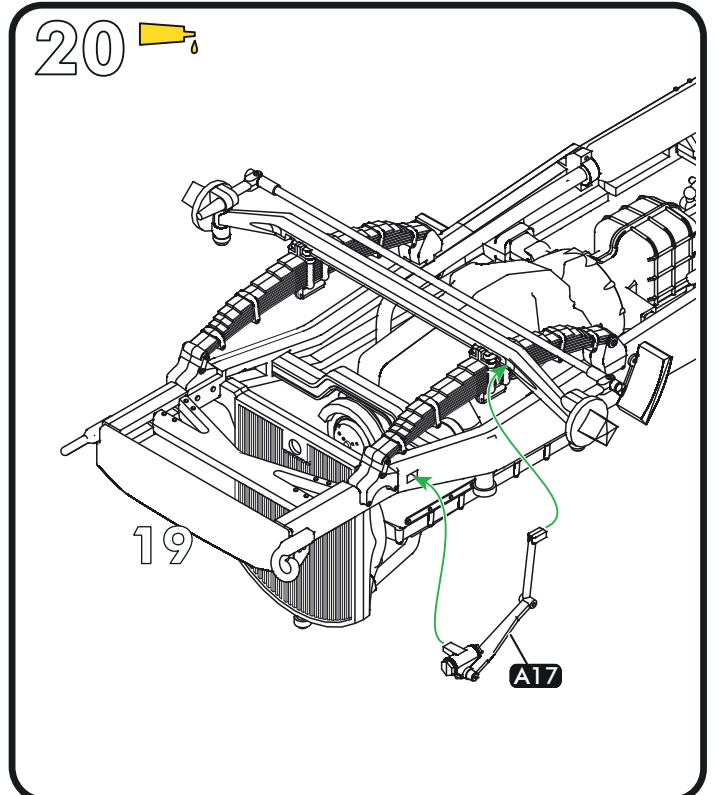
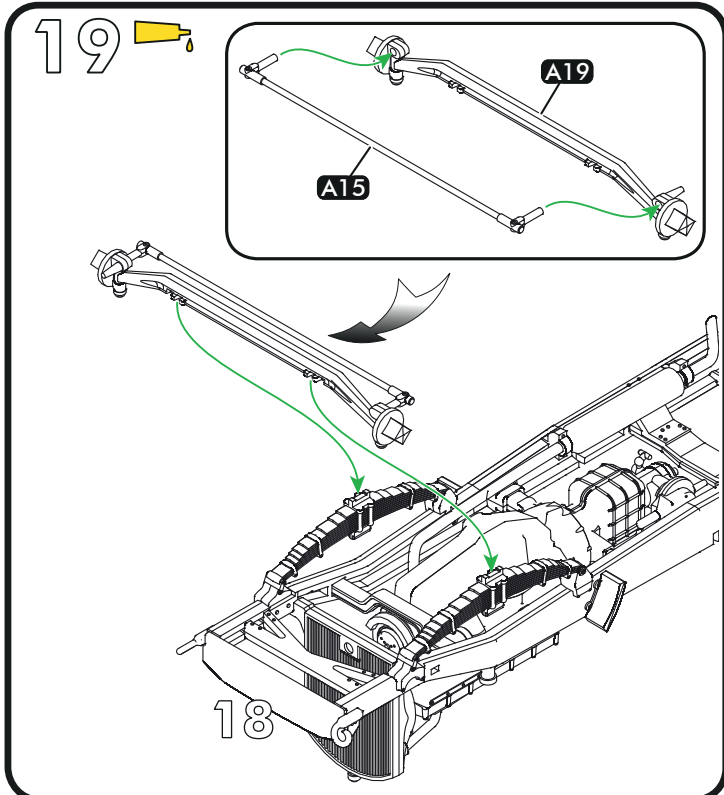
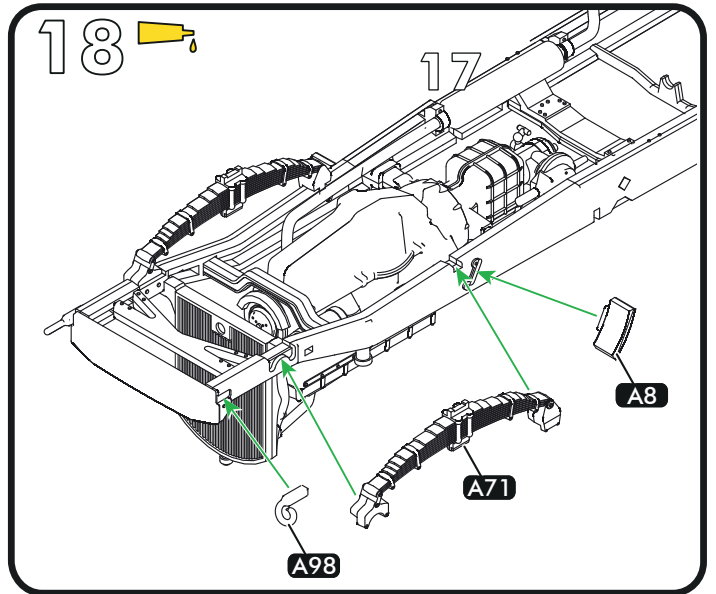
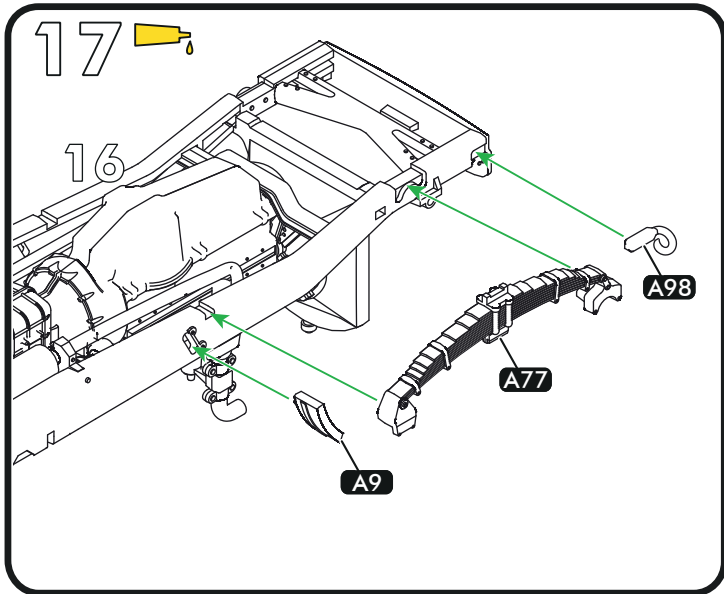
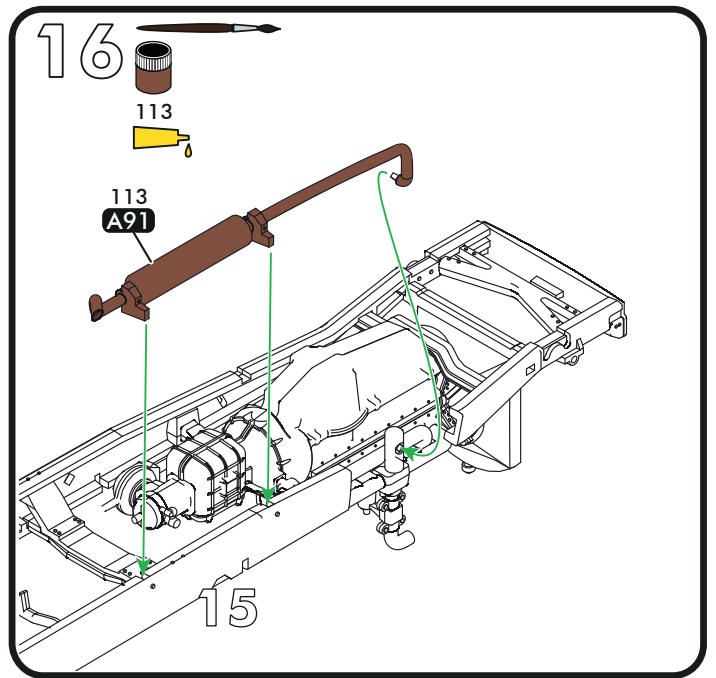
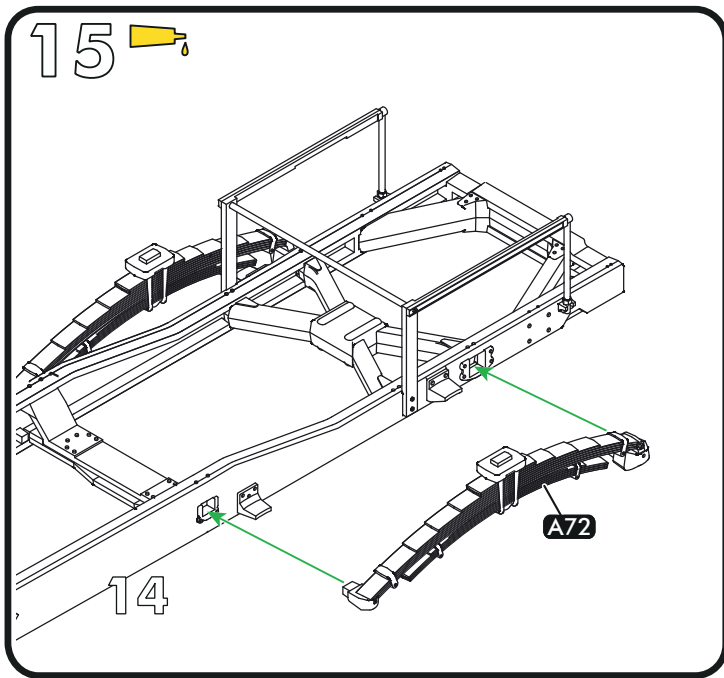

21 

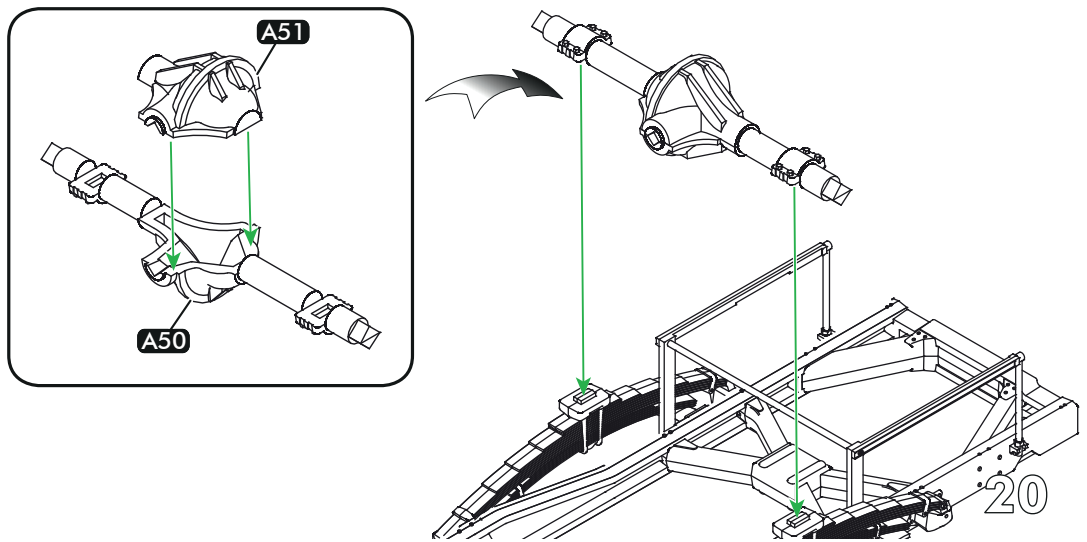

22 

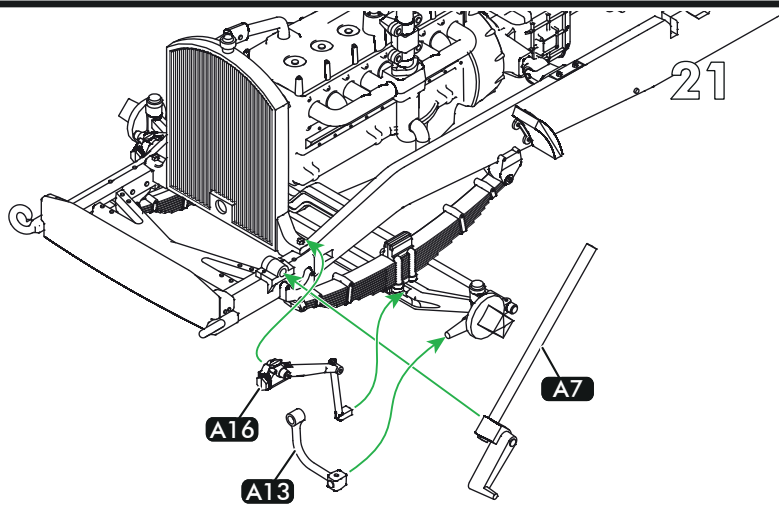

23 

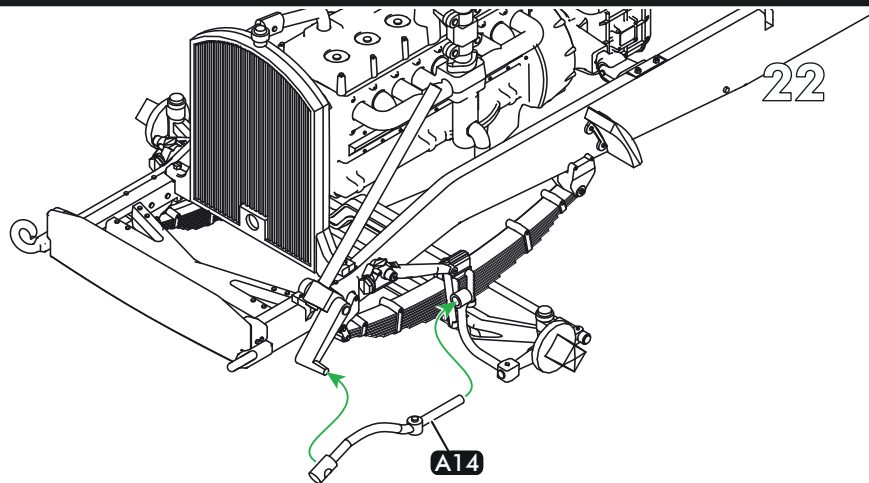

24 

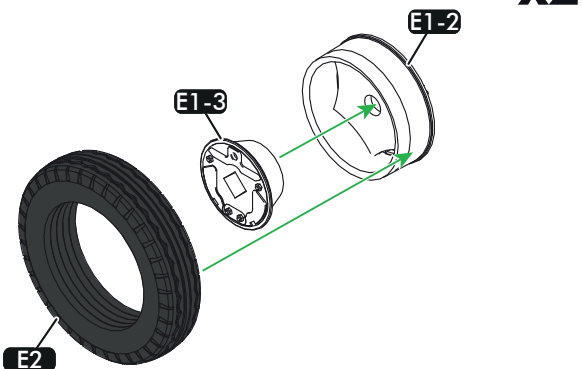

25 

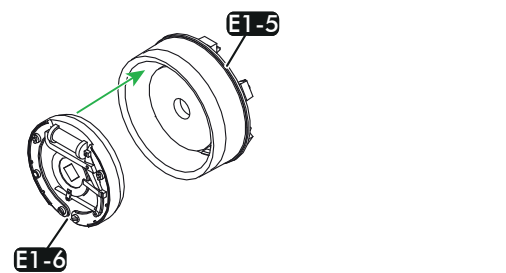

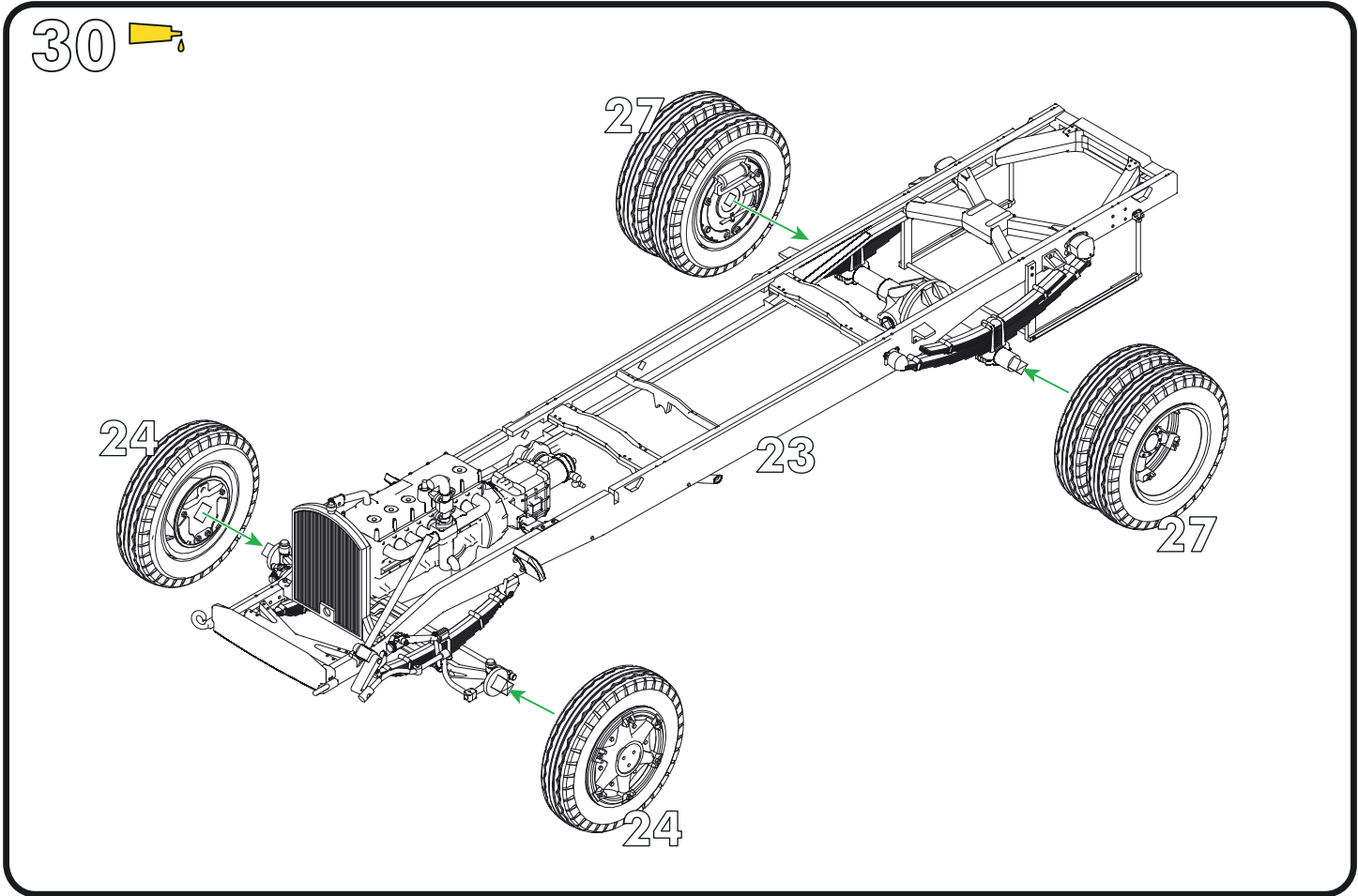
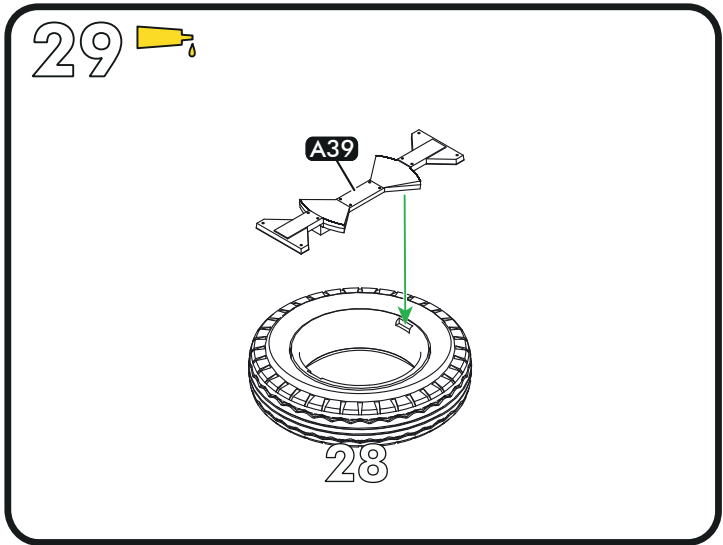
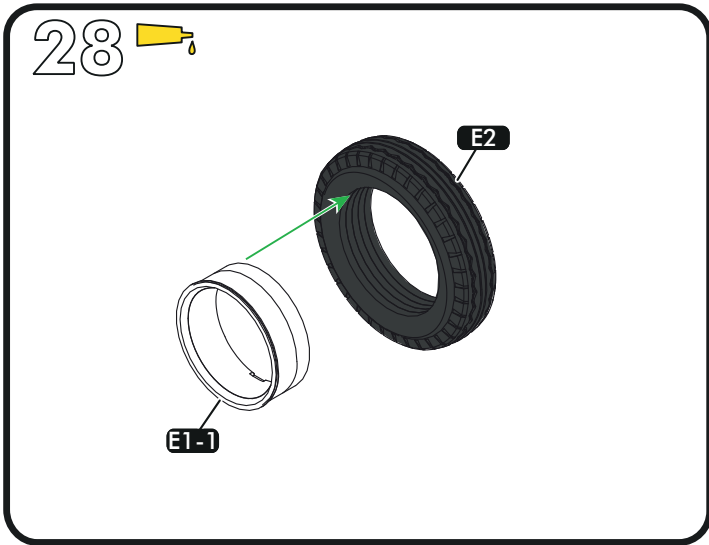
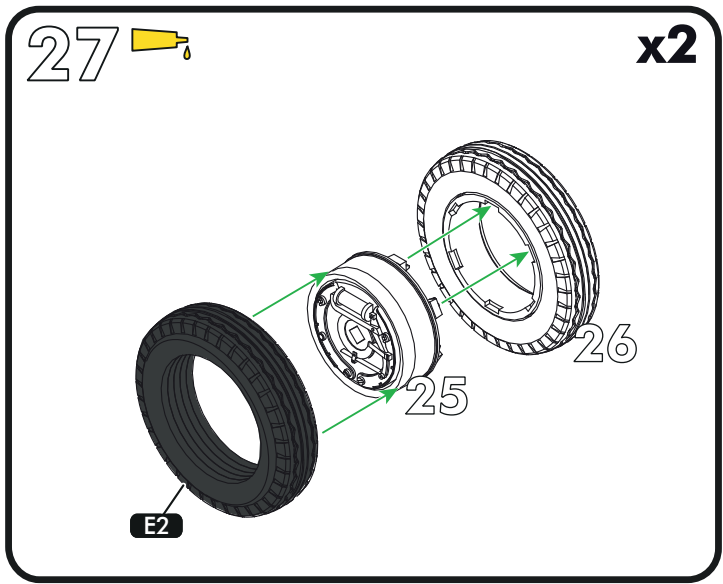
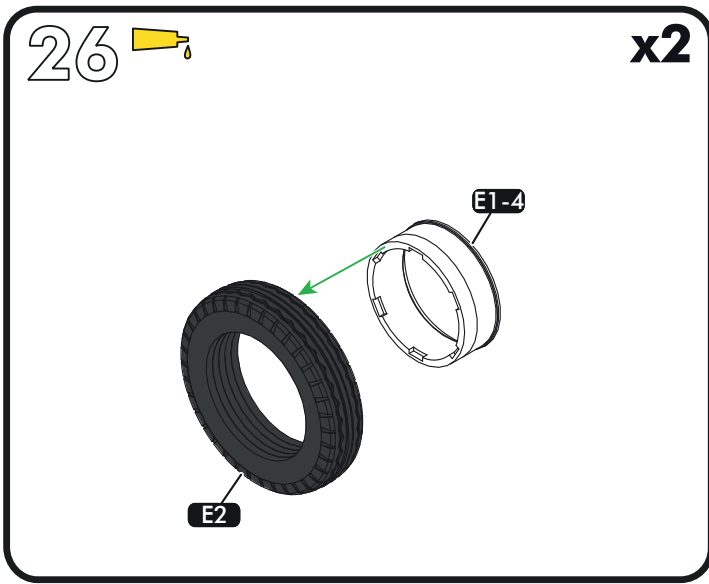



31 

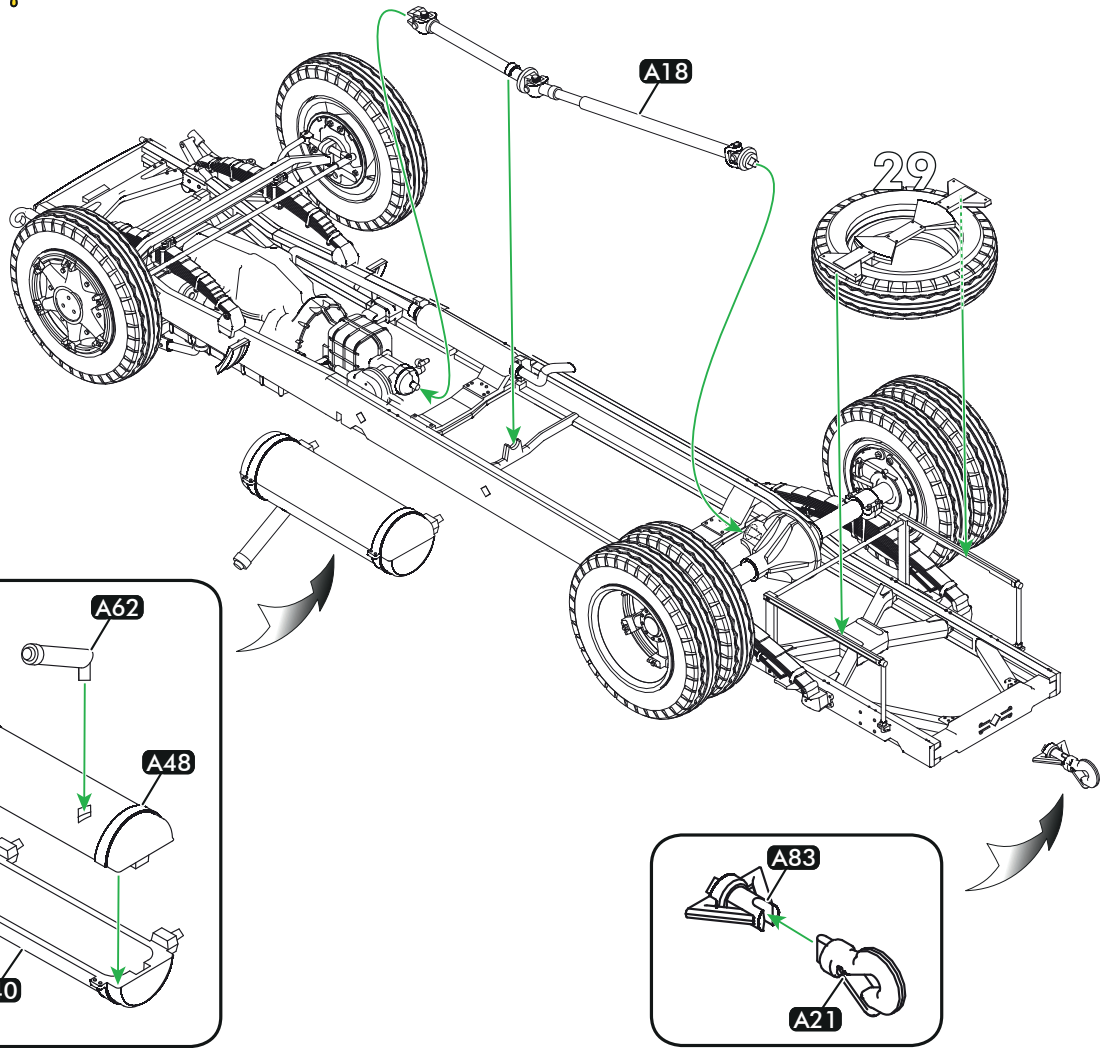

32 

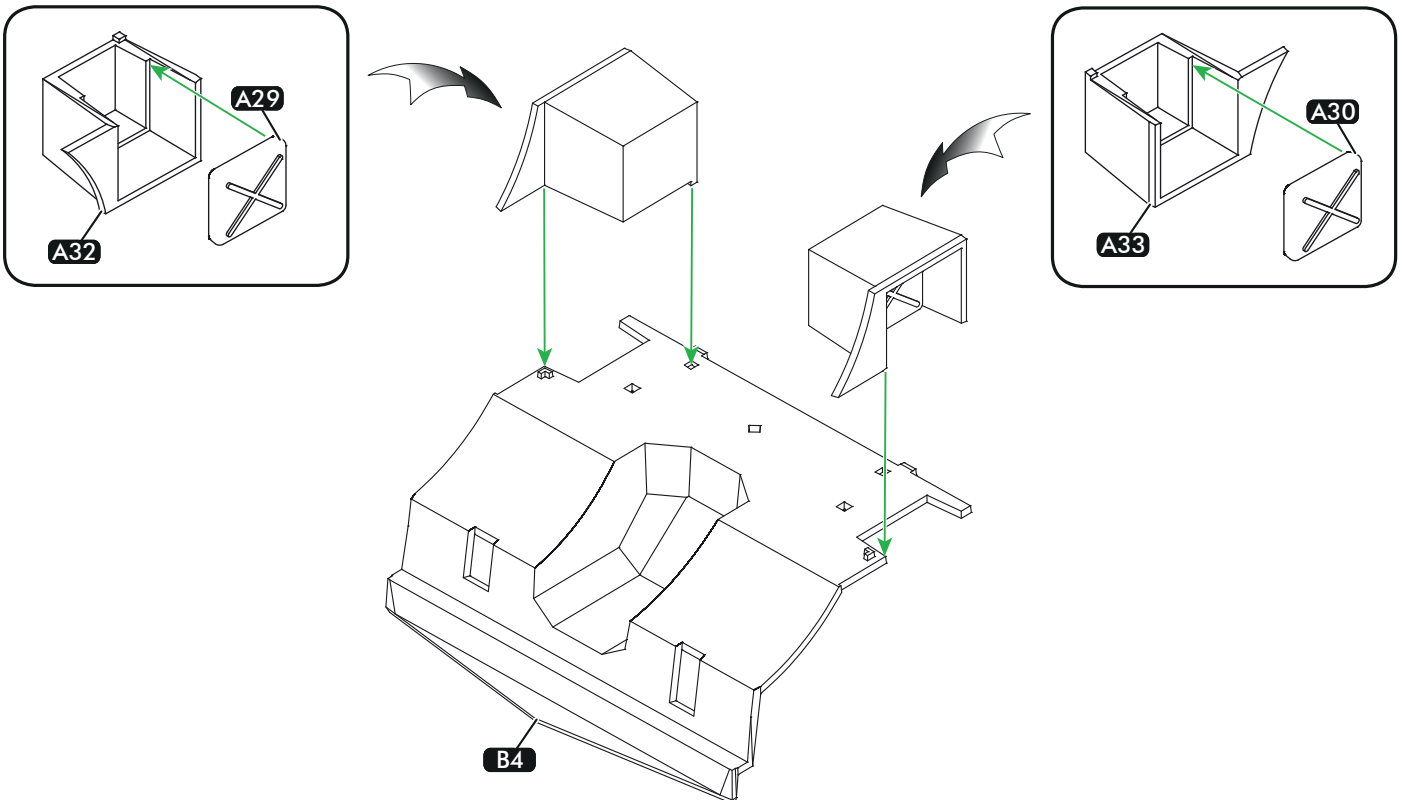

33 

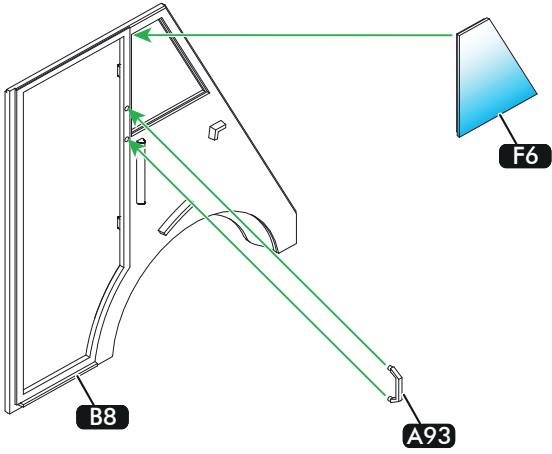

34 

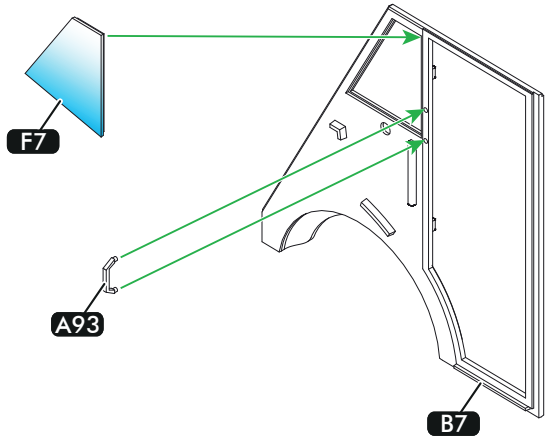

35 

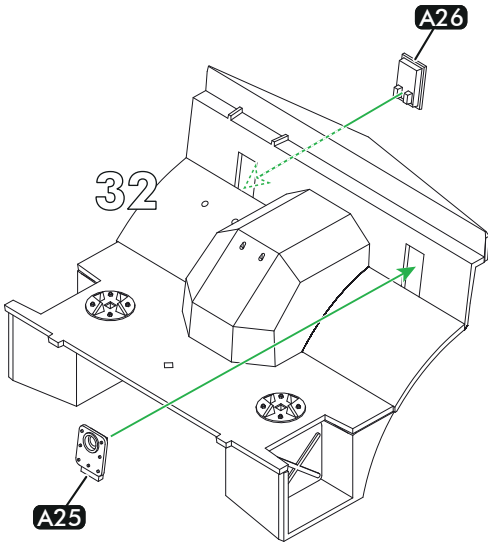

36 

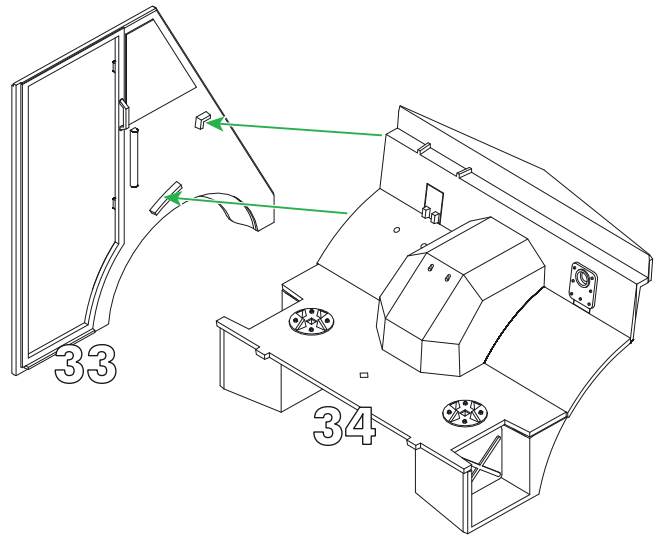

37 

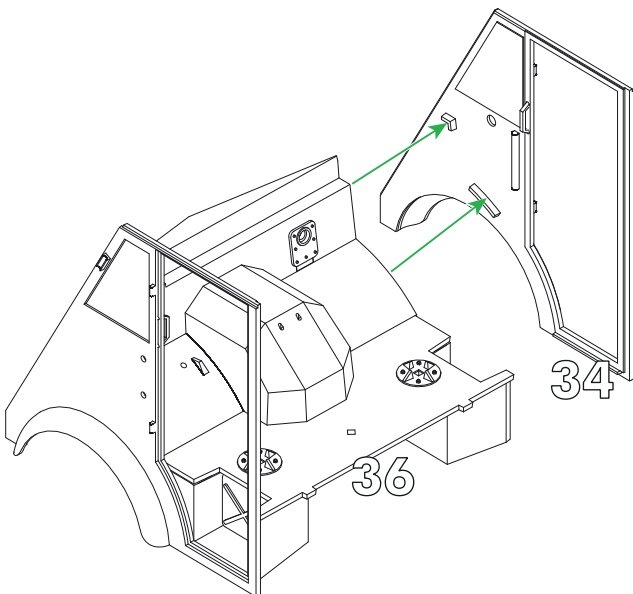

38 

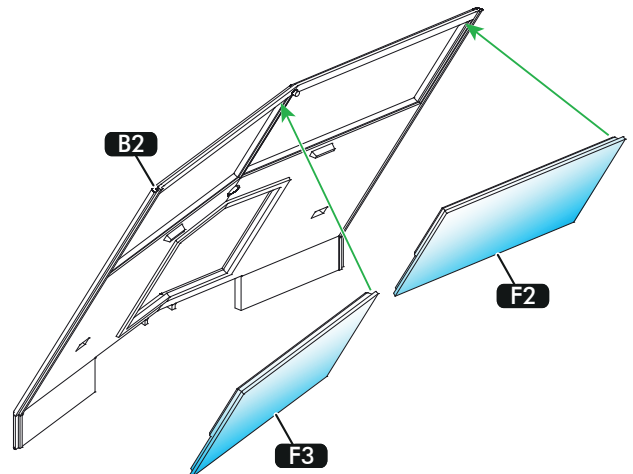

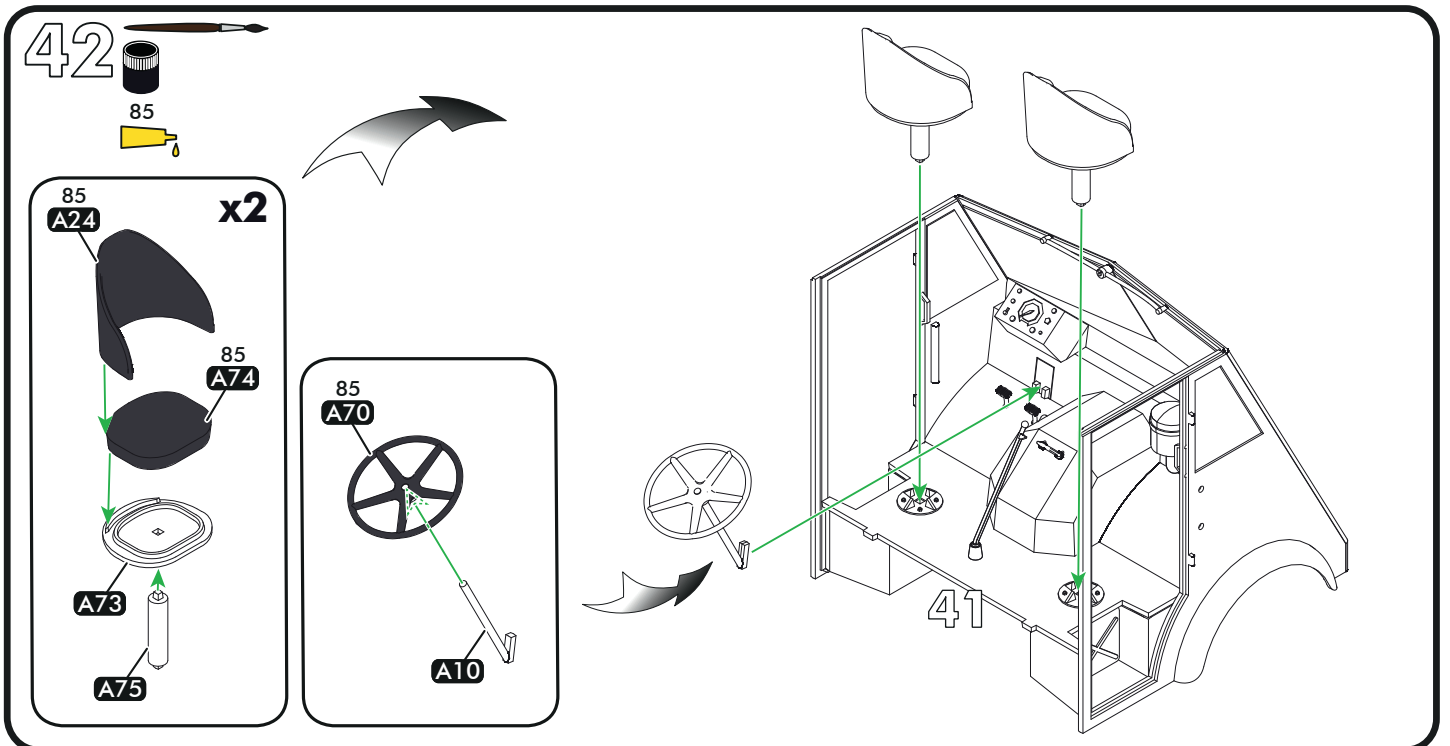
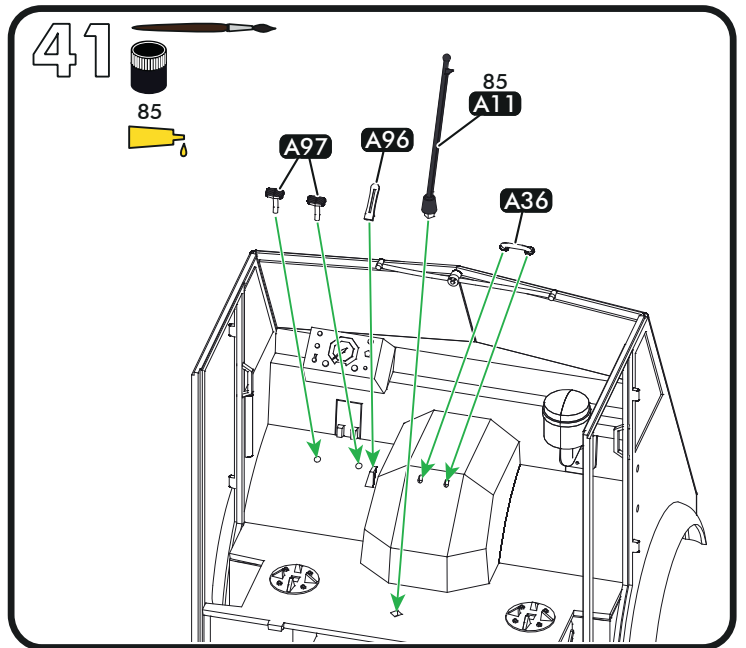
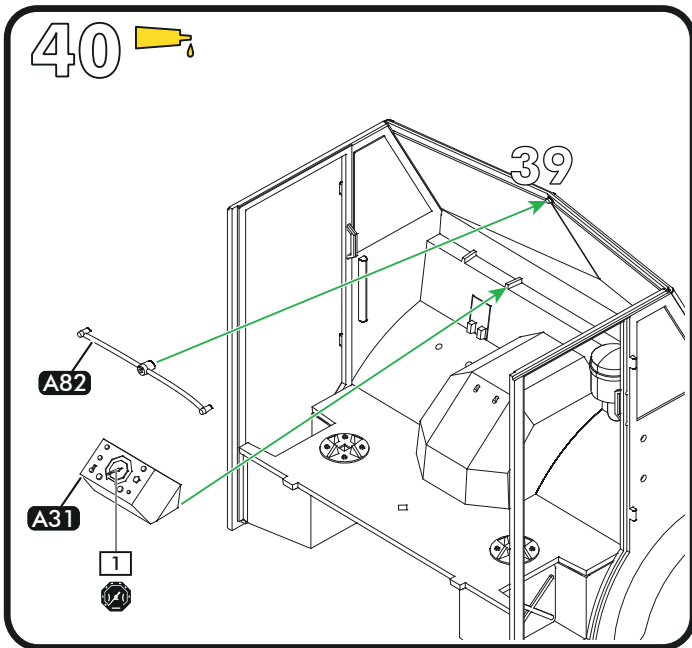
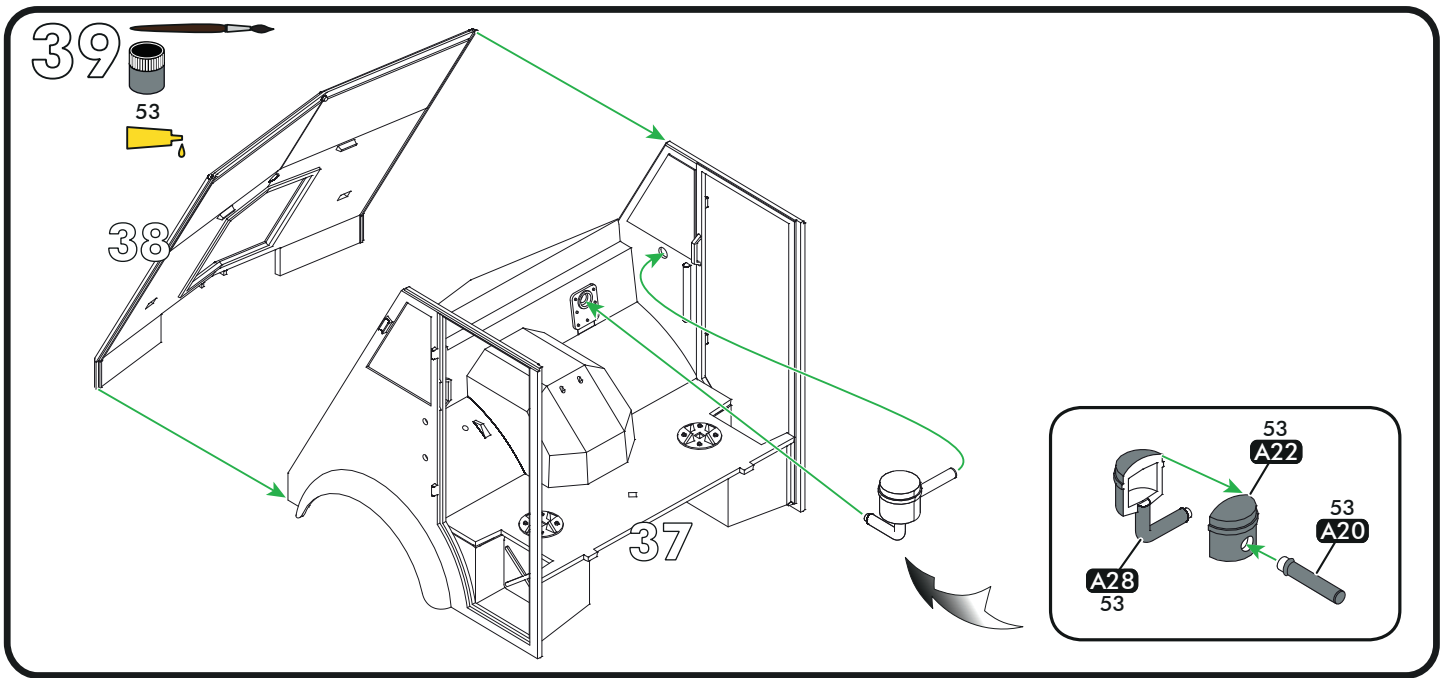

43 

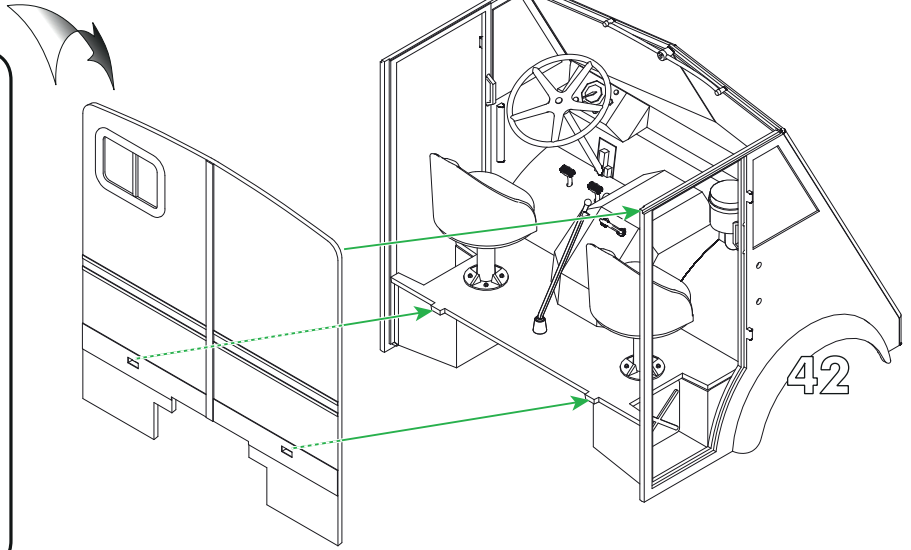
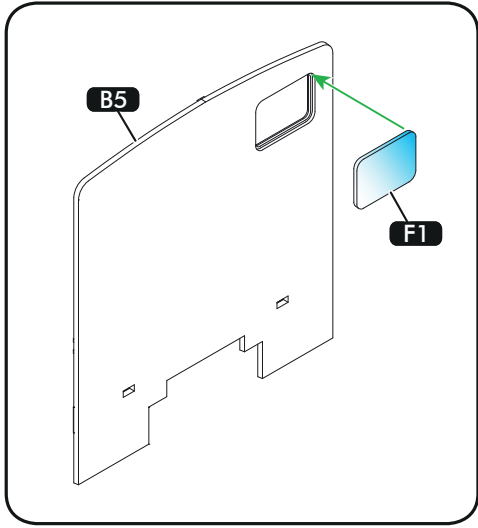

44 

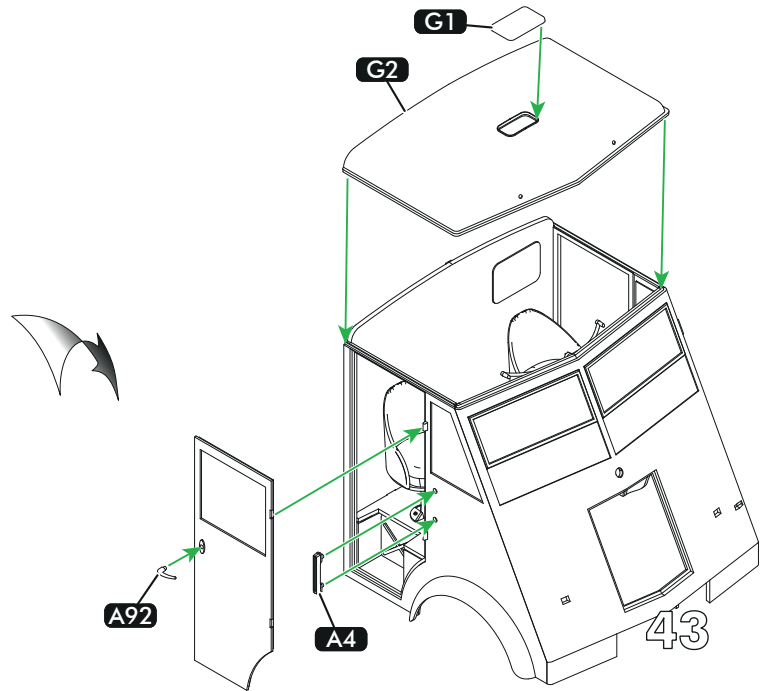
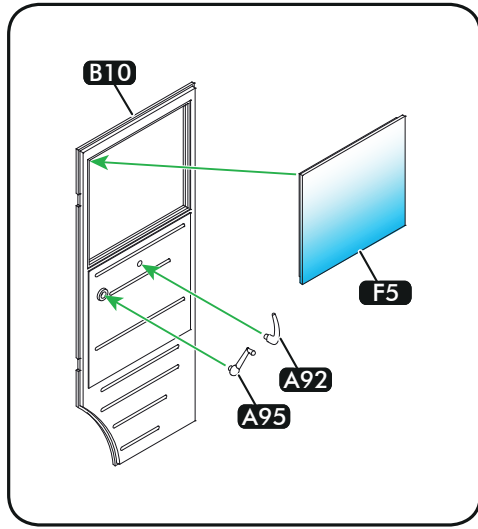

45 

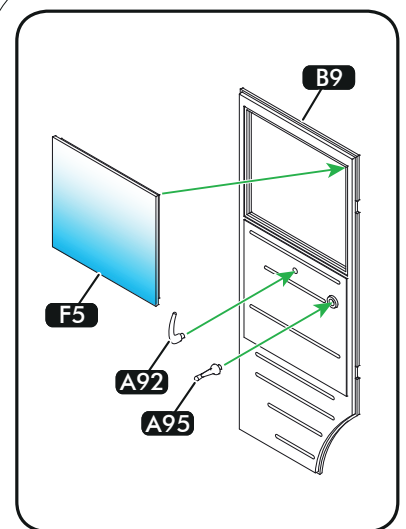
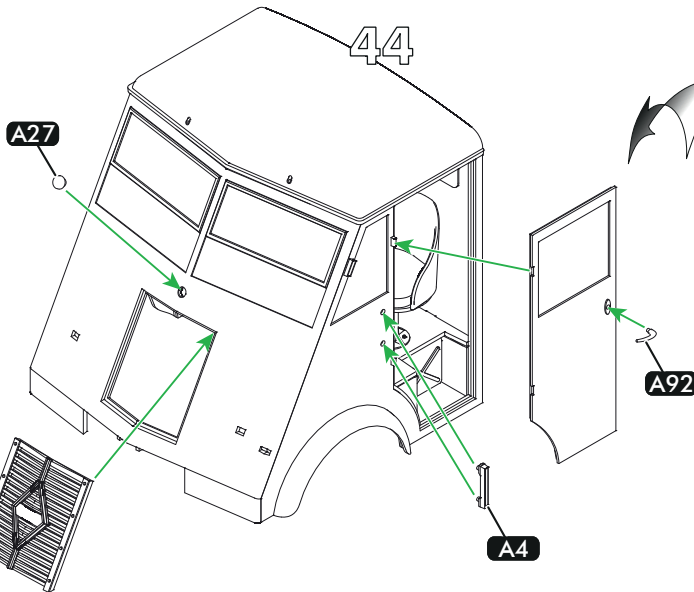
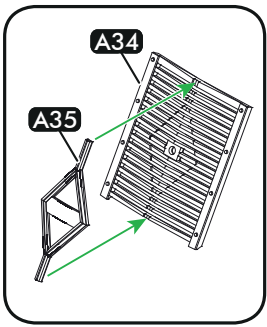

46 

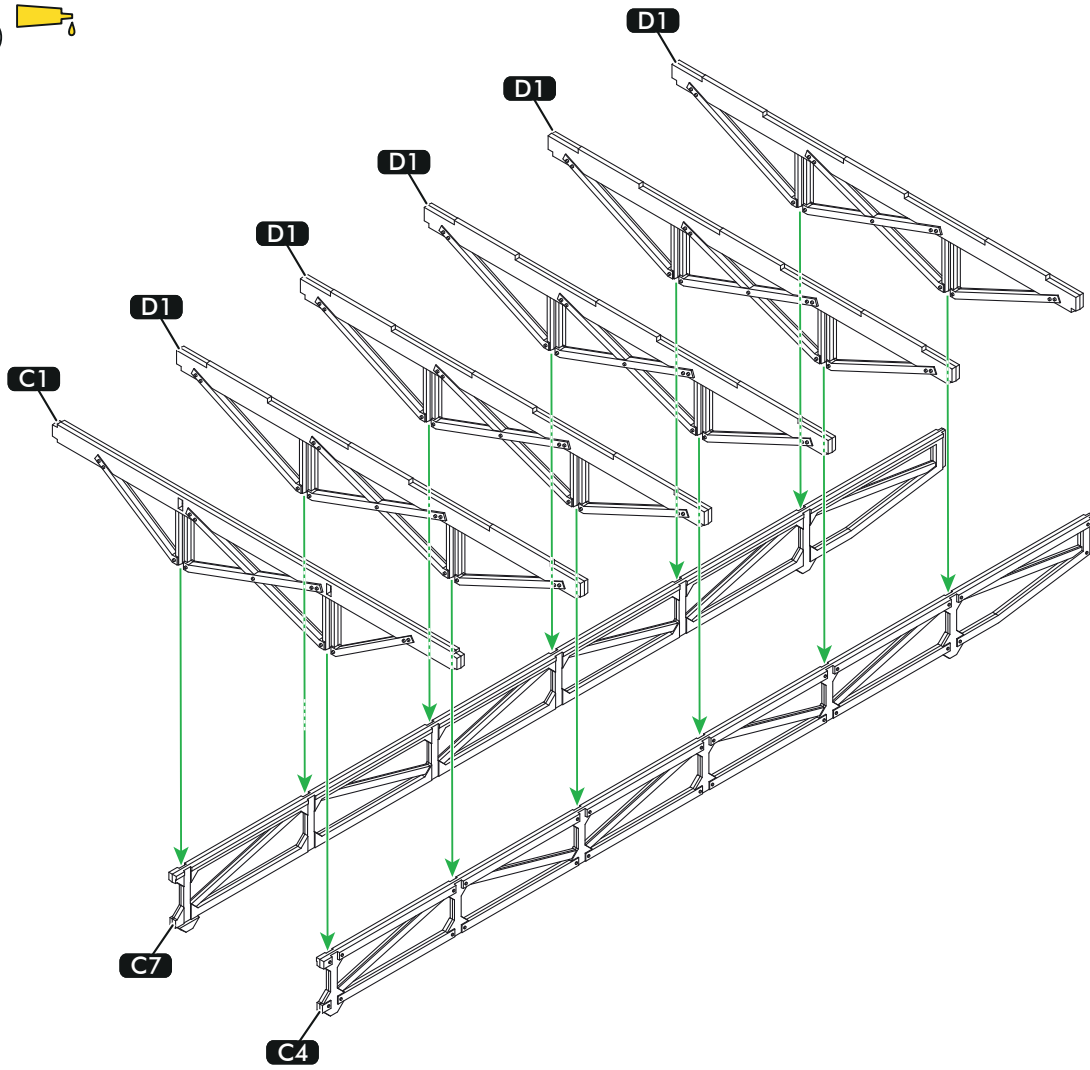

47 

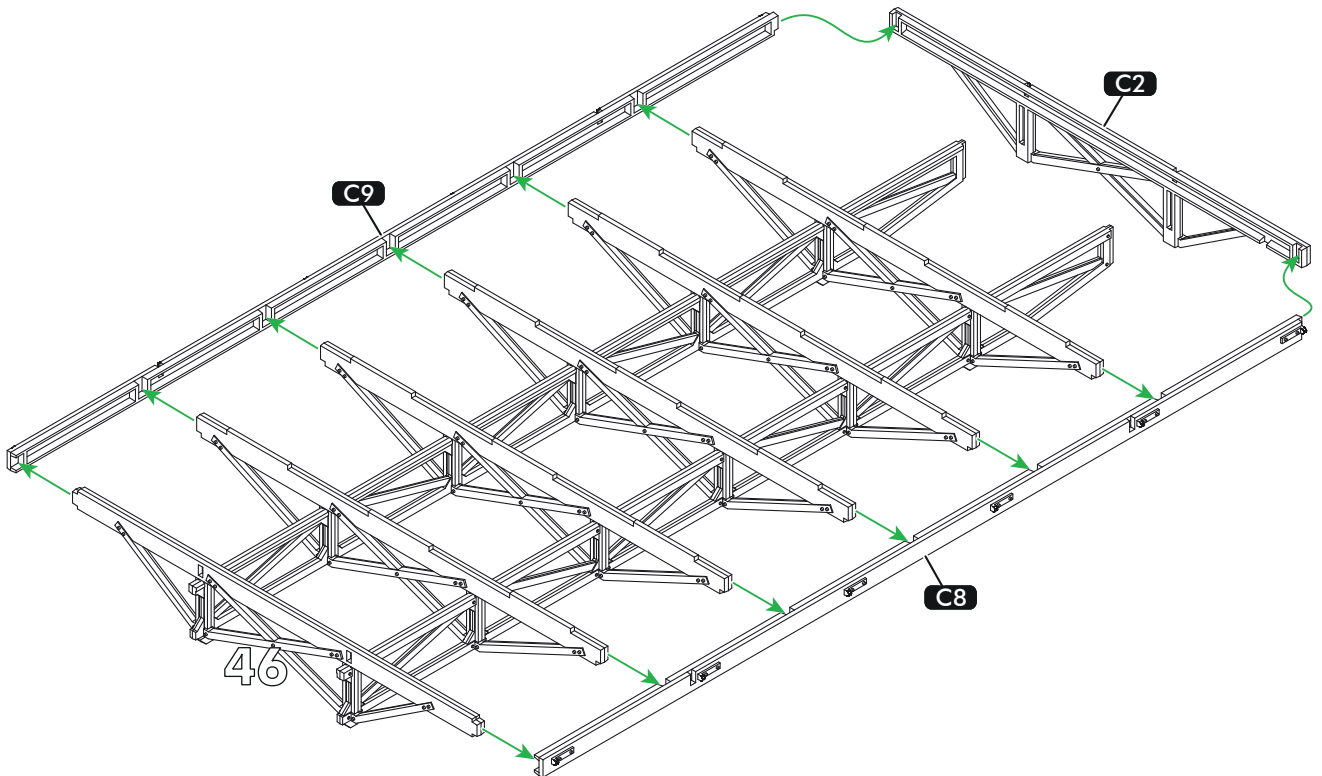

46

48 

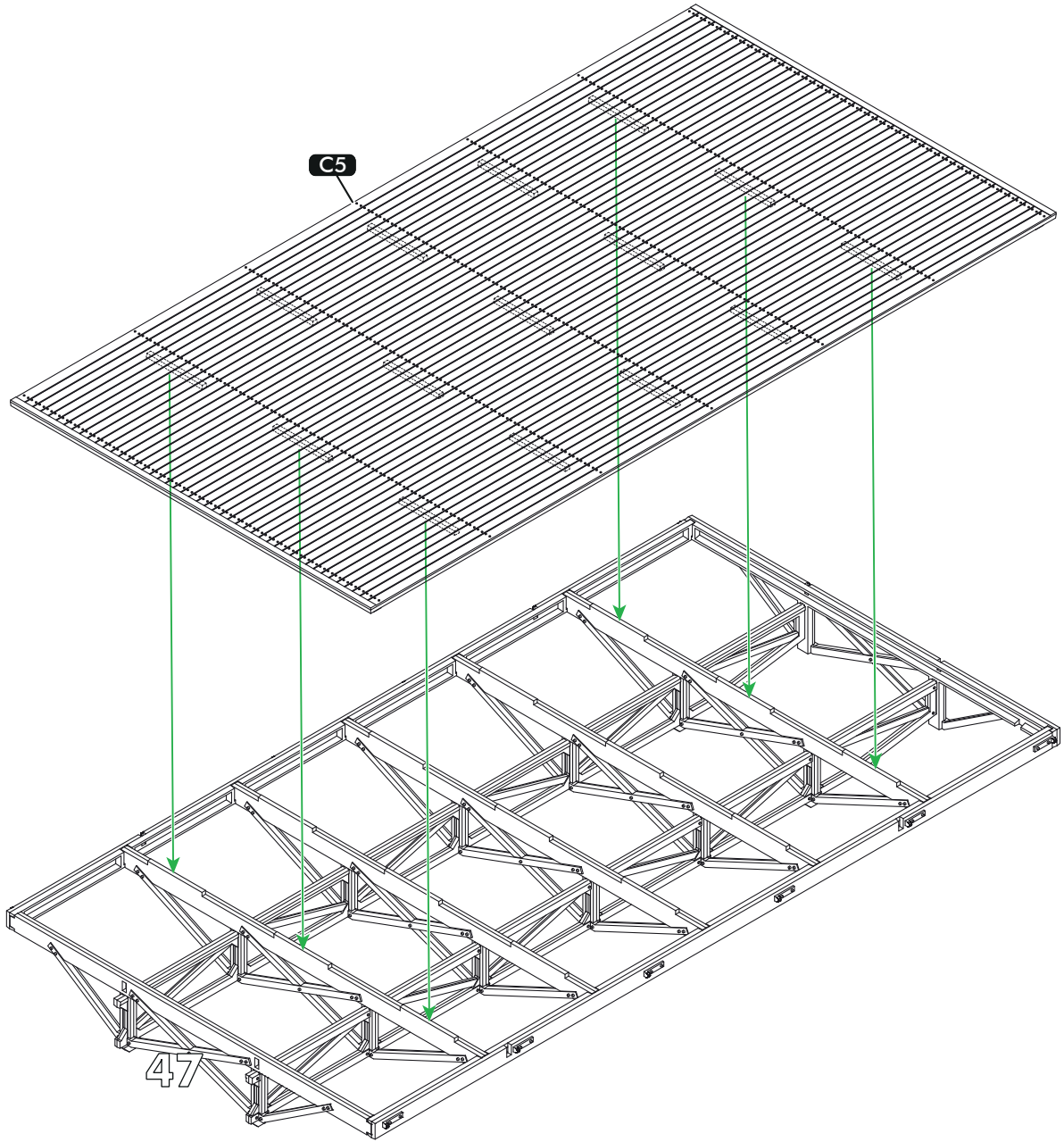

49 

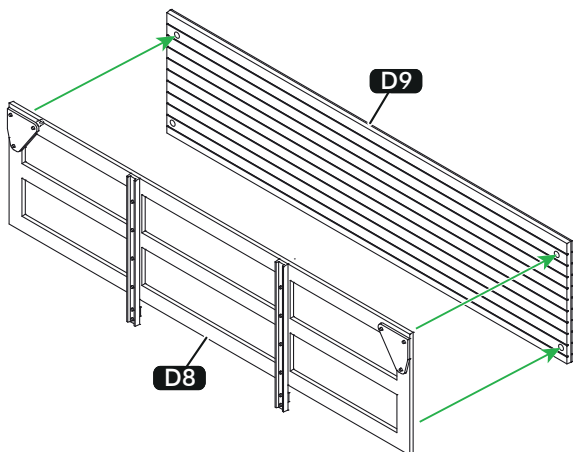

50 

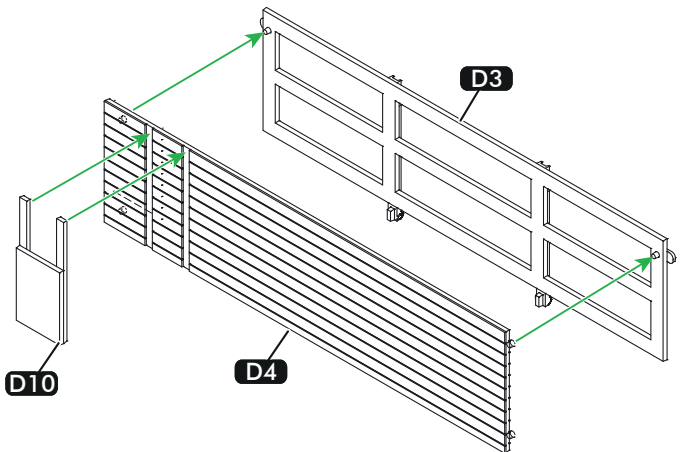

51 

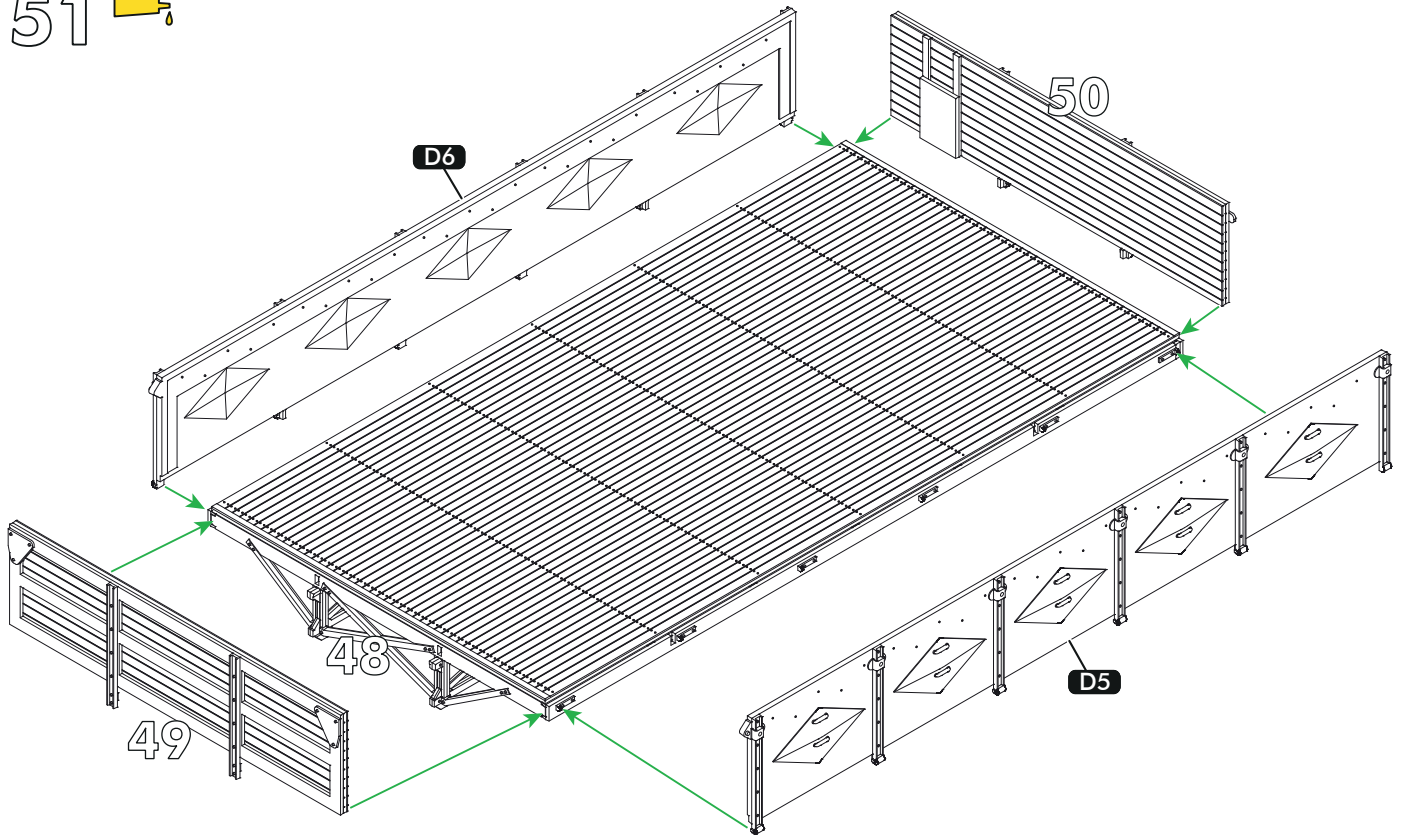

52 

19 

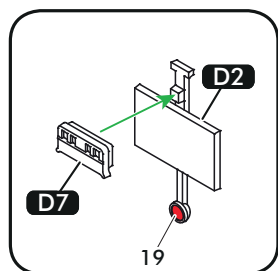
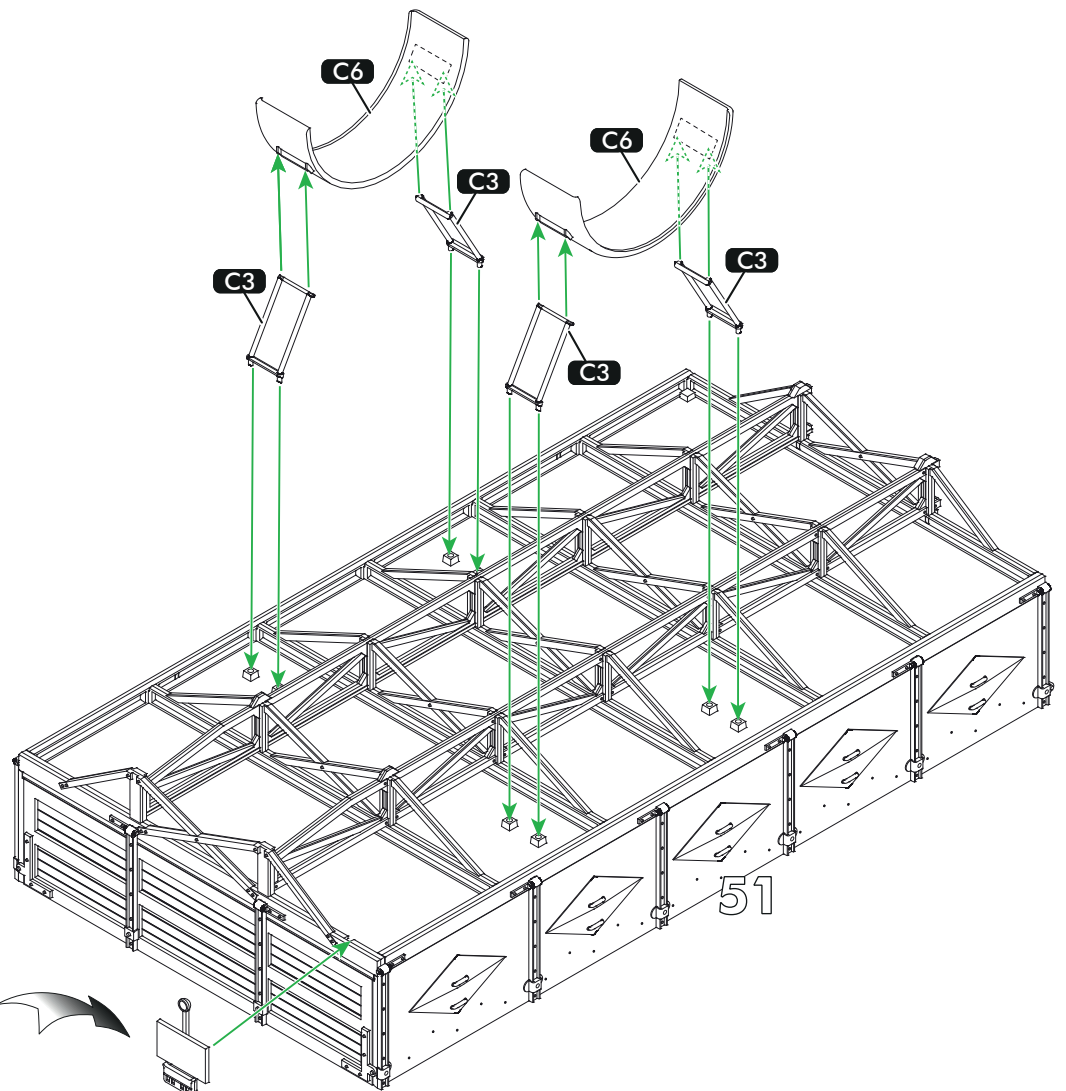

53 

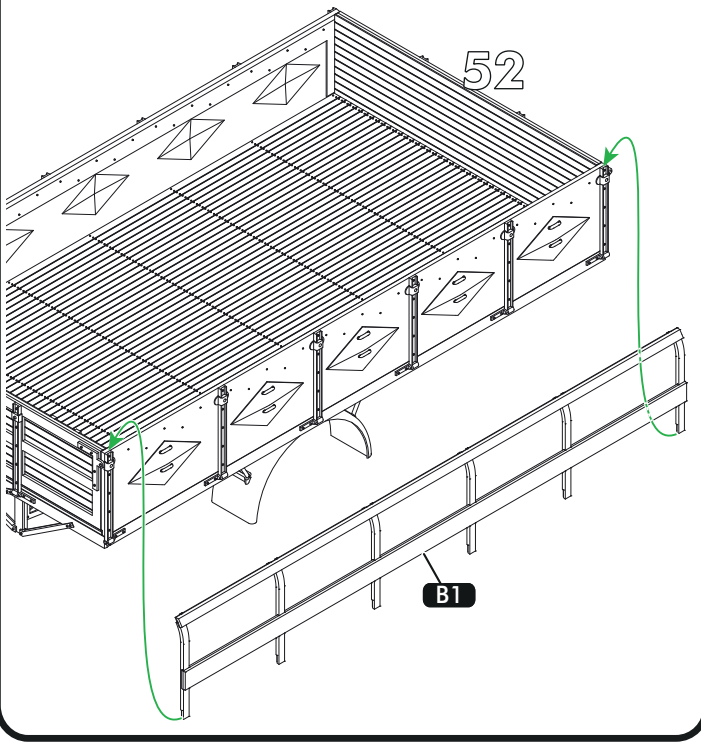

54 

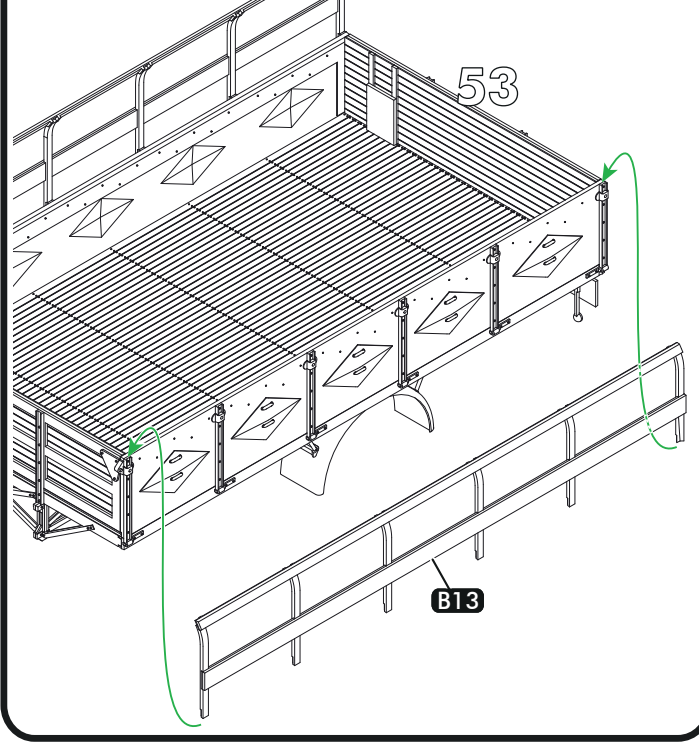

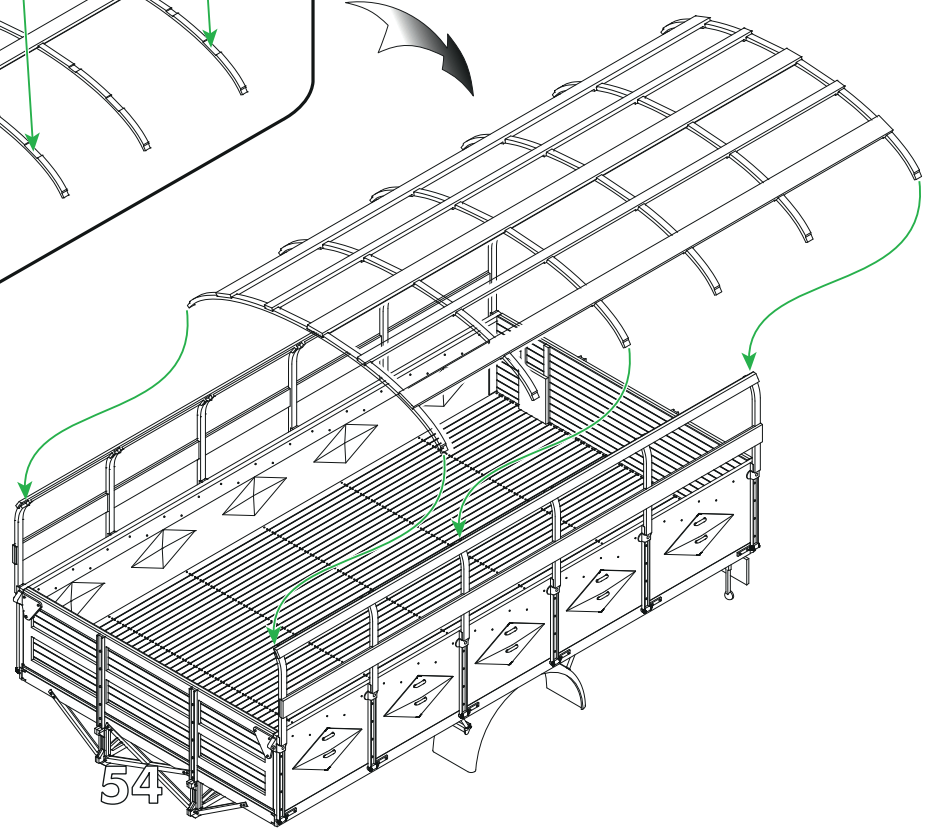
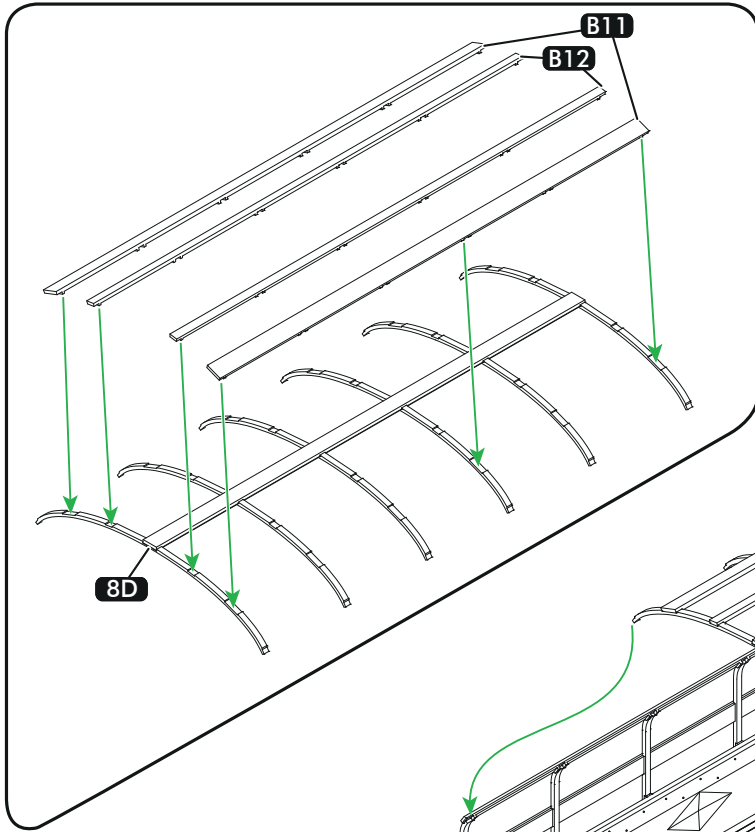

55 



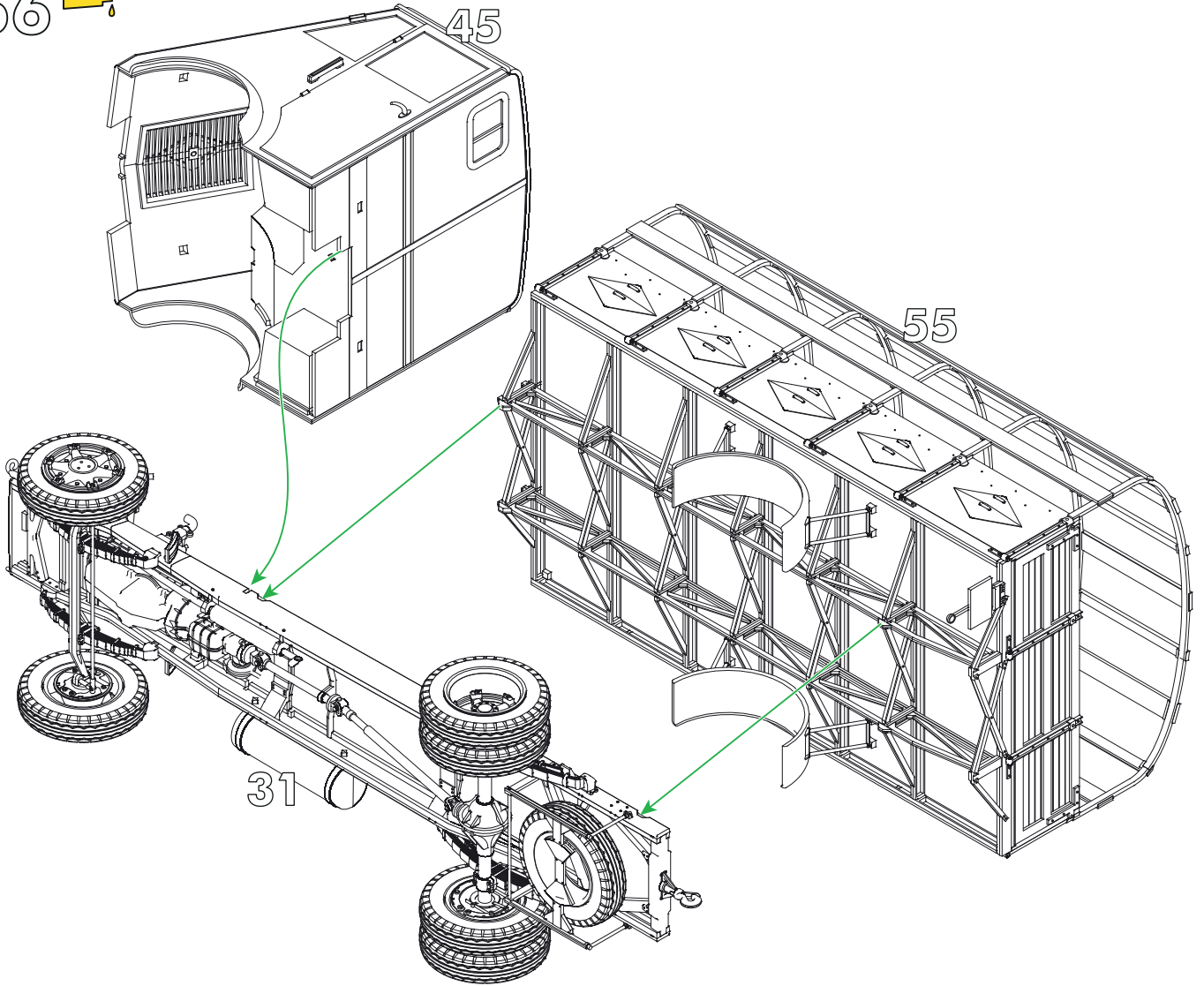

56 



57   
11 

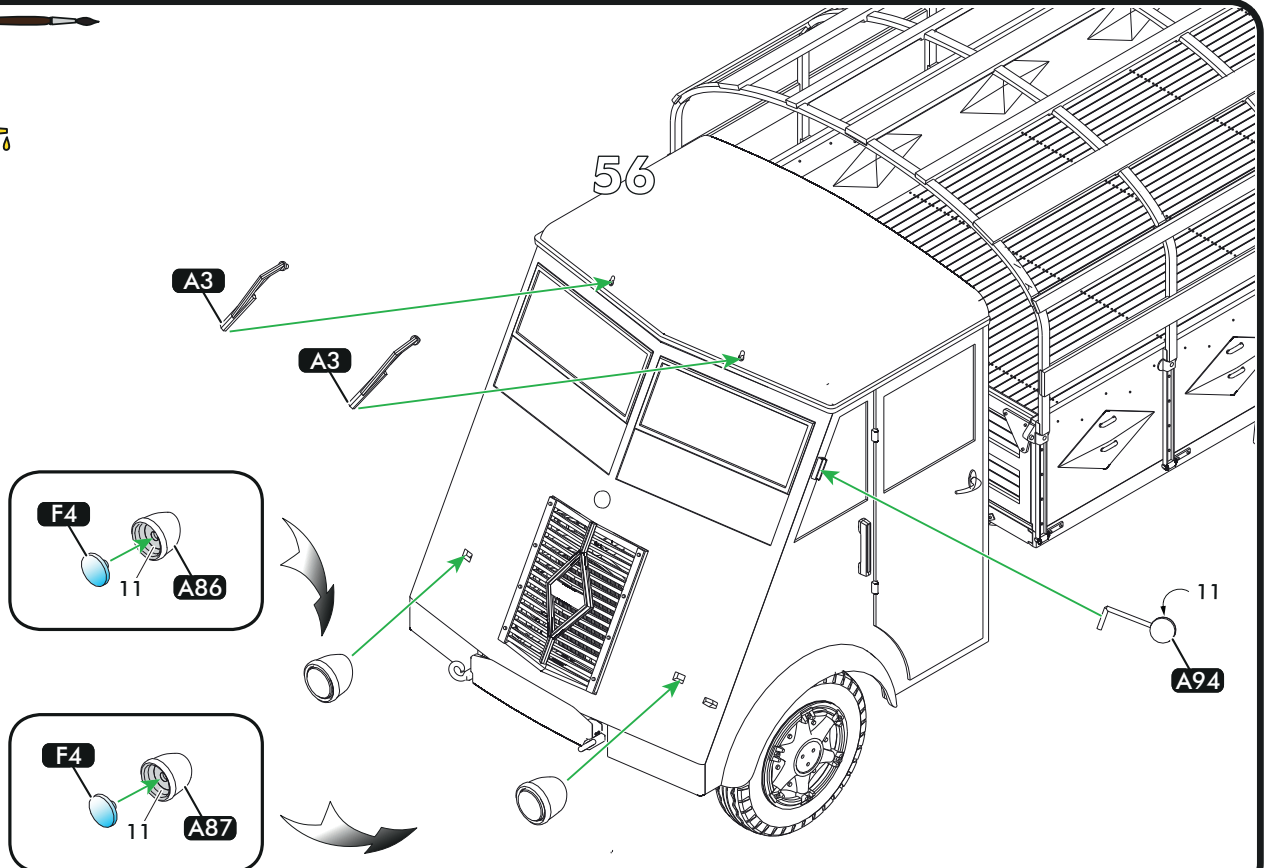

58

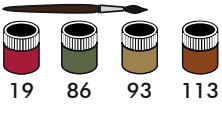

a - AHN capturé par les FFI (Forces Françaises de l'Intérieur), évocation, France, août 1944.  
 - AHN captured by the FFI (Forces Françaises de l'Intérieur), evocative, France, August 1944.

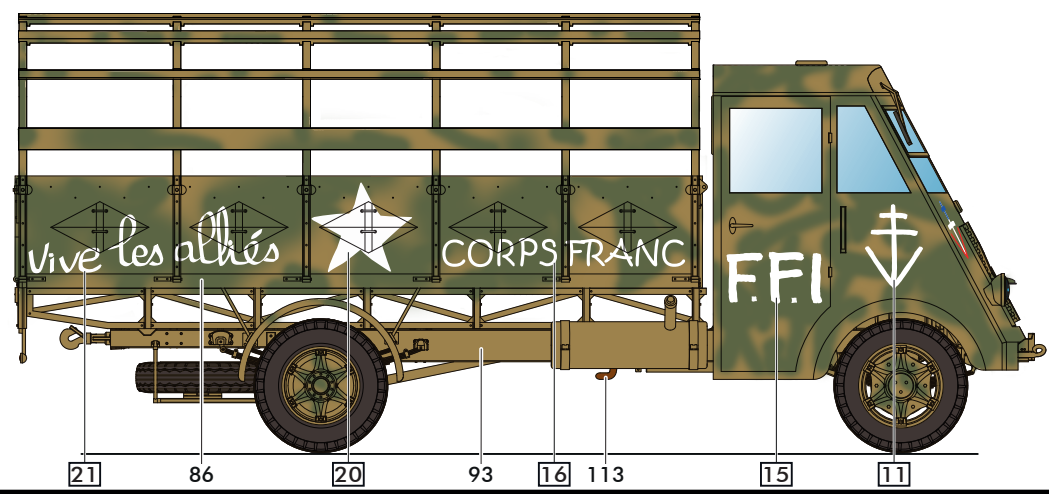
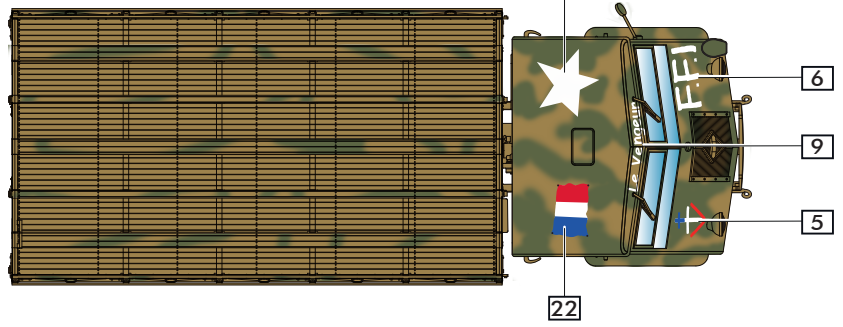
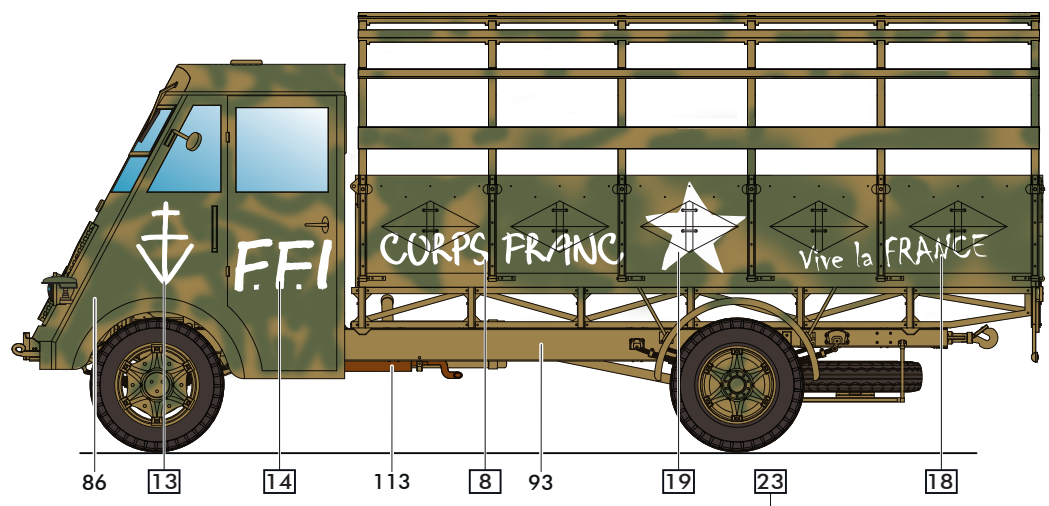
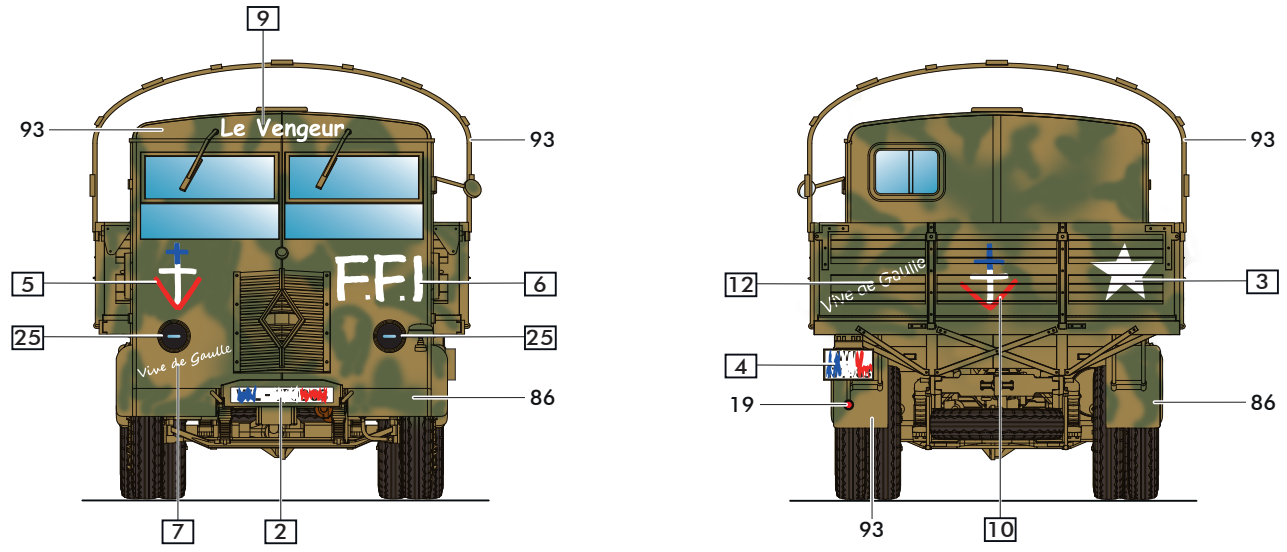

58

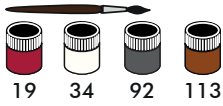

*b* - Lastkraftwagen 3,5 t AHN, 336<sup>e</sup> Division d'Infanterie, Taganrog, URSS, Automne 1942.  
 - Lastkraftwagen 3,5 t AHN, 336th Infantry Division, Taganrog, USSR, Autumn 1942.

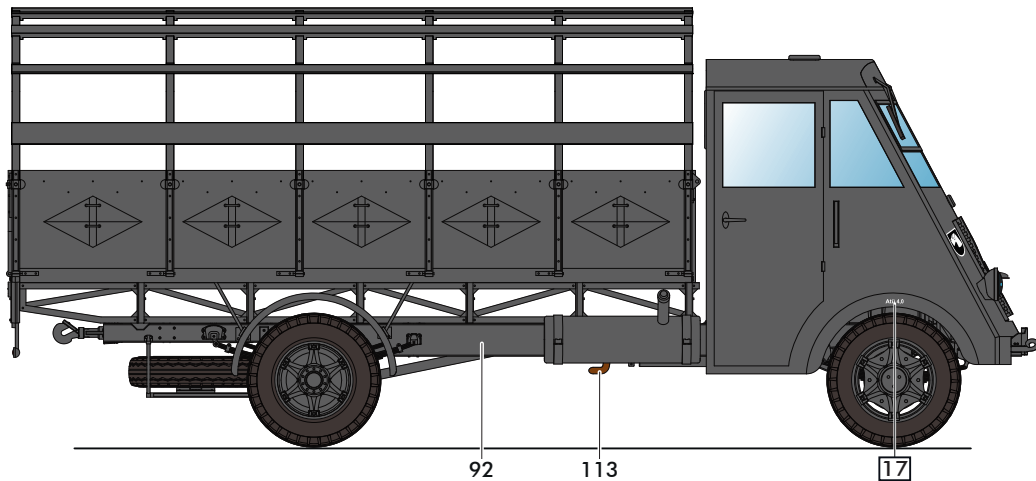
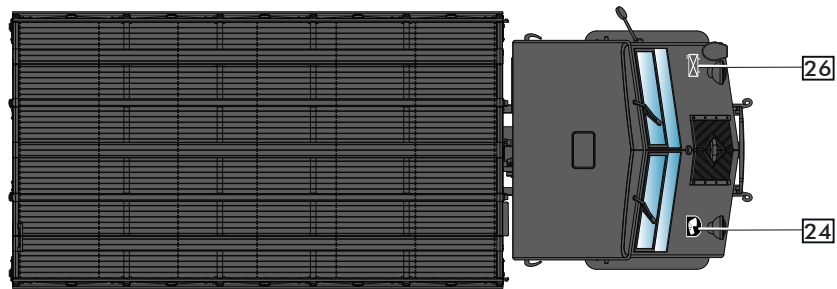
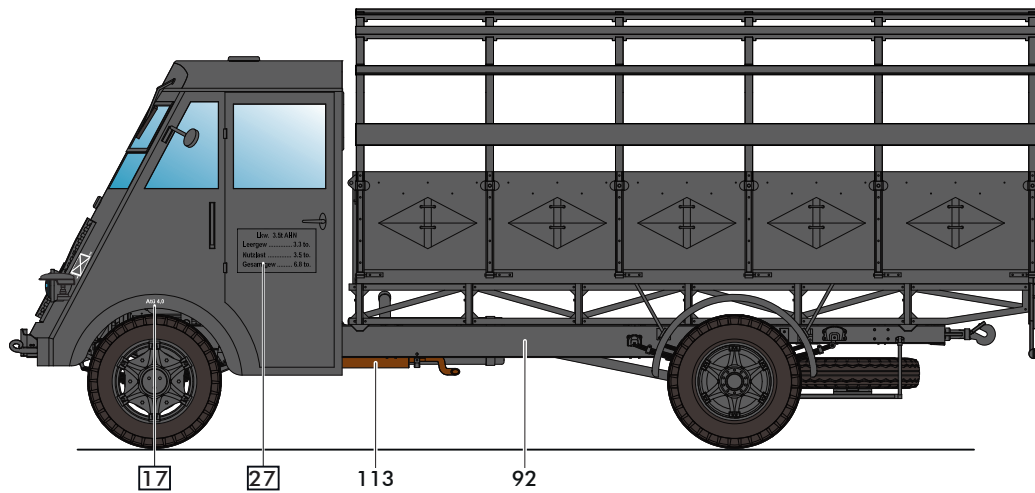
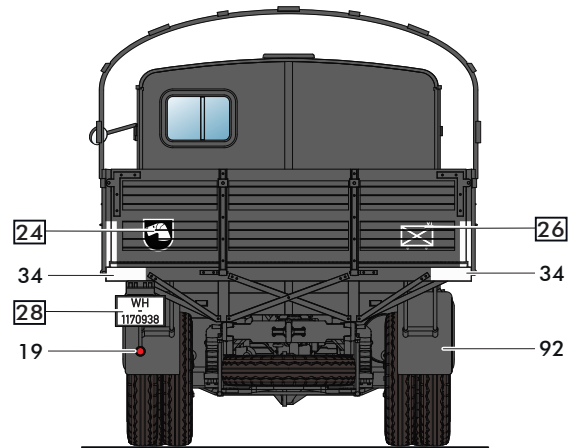
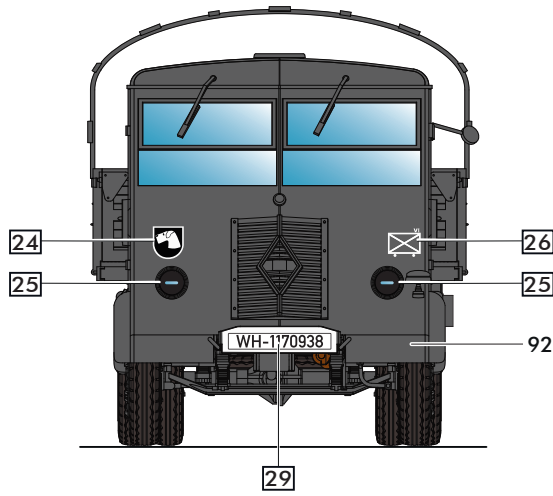

# VISITEZ-NOUS EN LIGNE !

VISIT US DIGITALLY!  
BESUCHEN SIE UNS DIGITAL!

 [www.heller.fr](http://www.heller.fr)

 [instagram.com/heller.fr](https://www.instagram.com/heller.fr)

 [facebook.com/heller.fr](https://www.facebook.com/heller.fr)

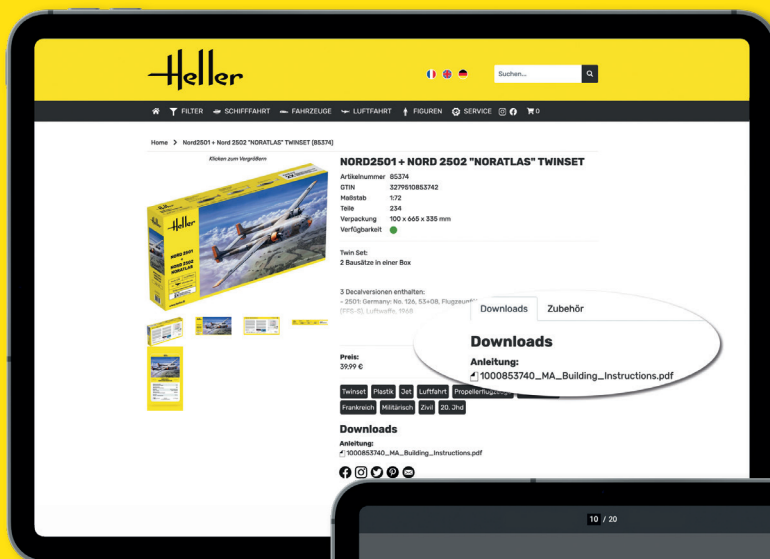

Choisissez l'article désiré et téléchargez la notice de montage.

Choose your desired article and download the instructions.

Wählen Sie den gewünschten Artikel und laden Sie die Anleitung herunter.

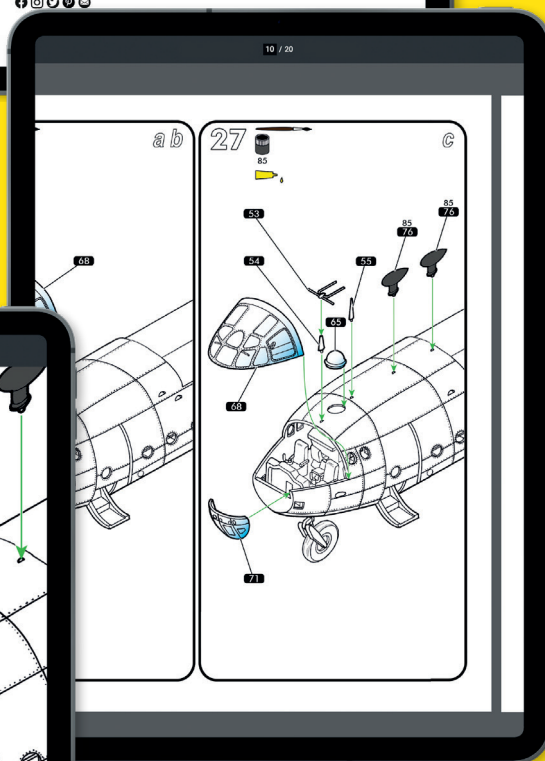

**Download all instructions!**

Grossissement des instructions pour une vue détaillée.

Enlarge the instructions for a more detailed view.

Vergrößern Sie die Anleitung für eine detailliertere Ansicht.

V-050124

**Service consommateurs**  
Pour toute demande de SAV, connectez-vous sur notre site [www.heller.fr](http://www.heller.fr).

**Customer Service**  
For after-sales service requests, please contact us through our website [www.heller.fr](http://www.heller.fr).

**Endverbraucherservice**  
Bitte besuchen Sie uns auf [www.heller.fr](http://www.heller.fr) für alle Ersatzteilanfragen.

**Heller Hobby GmbH**

Erlenbacher Str. 3 • 42477 Radevormwald • GERMANY

+49 (0) 2195-92773-0 [info@heller.fr](mailto:info@heller.fr)