

Heller

CITROËN HY 1957/1964

80744



DÉCOUVREZ LE MONDE DES PEINTURES ACRYLIQUES HELLER !

DISCOVER THE WORLD OF HELLER ACRYLIC PAINTS!

ENTDECKEN SIE DIE WELT DER HELLER ACRYL-FARBEN!

NEW



- FACILE À UTILISER
- DILUABLE À L'EAU
- POTS DE PEINTURE STABLES
- BOUCHON À VIS SÉCURISÉ

- EASY TO USE
- DILUTABLE WITH WATER
- STABLE PAINT CANS
- SECURE SCREW CAP

- EINFACHE ANWENDUNG
- MIT WASSER VERDÜNNBAR
- STANDFESTE FARBDOSEN
- SICHERER SCHRAUBVERSCHLUSS

Français

C'est un fourgon automobile permettant de charger 1200 kg de marchandises dans un volume de 7,3 m³. Il fut conçu par Pierre Franchiset à qui il doit son nom, le «H», car c'est le huitième projet de ce type développé par Citroën, le H étant la huitième lettre de l'alphabet. Sa conception est basique et il reprend beaucoup d'éléments d'autres véhicules de la marque: moteur et boîte de vitesse de la Traction, volant, compteur, essuie-glace de la 2cv. Il fut présenté au public en 1947 et il reçut différentes motorisations (1600 cm³, 1900cm³, 16cv, 11cv) au cours de sa longue carrière (34 ans), pendant laquelle plus de 473 000 exemplaires furent produits. En fonction de la charge et de sa carrosserie, l'appellation commerciale changeait, H (1200 kg de charge utile), HZ (850 kg - 1000 kg), HY (1500 kg puis 1600 kg, 1966), HP (plateau), HX (plateau frigorifique) ou HW (plateau carrossier). Le dernier exemplaire sorti des chaînes de montage en décembre 1981 (n°4732) Installé 128 Rue de Lille à Neuville Saint Rémy, aux portes de Cambrai (59), le garage ACIER a été créé en 1971 par le rachat d'un garage PANHARD par Monsieur et Madame Acier. D'entreprise familiale avec un salarié, c'est aujourd'hui une SARL employant 6 salariés et un apprenti.

English

Designed by Pierre Franchet who gave it its name « type H » (as the eighth such project developed by Citroën, H being the eighth letter in the Latin alphabet), this van was intended to carry a load of 1200 kg in a volume of 7,3 m³. Its design was utilitarian and re-used many components from other vehicles of the brand-name : engine and gearbox came from the Traction Avant, and steering wheel, dashboard and wipers from the 2CV. Introduced to the general public in 1947, it received different types of engines (1600 cm³, 1900 cm³, 16 cv, 11 cv) during its 34-year long career. Over 473 000 units were rolled out during its production time. Depending on the load-carrying ability and the body, a second letter was added to the commercial designation: H for a payload capacity of 1200 kg, HZ for 850 to 1 000 kg, HY for 1500 kg (increased to 1600kg in 1966), HP was a flatbed variant, HX was a refrigerated van, and HW was a flatbed with folding sidewalls. In December 1981, the last unit, chassis number 473289, left the assembly line. Located 128 Rue de Lille in Neuville Saint Rémy, at the gates of Cambrai (59), the ACIER garage was created in 1971 by the purchase of a PANHARD garage by Mr. and Mrs. Acier. From a family business with one employee, it is today a LLC with 6 employees and an apprentice.

Deutsch

Der Citroen Fourgon Typ H war ein Lastkraftwagen der 1200 kg Güter mit einem Volumen von 7,3 m³ laden konnte. Er wurde von Pierre Franchiset entworfen, dem er auch seinen Namen verdankt, das „H“, denn es war das achte Projekt dieser Art, das von Citroën entwickelt wurde, wobei das „H“ auch der achte Buchstabe des Alphabets ist. Sein Design war einfach und er verwendete viele Elemente aus anderen Citroën-Fahrzeugen: Motor und Getriebe aus dem Traction, Lenkrad, Tachometer und Scheibenwischer aus dem 2CV. Er wurde 1947 der Öffentlichkeit vorgestellt und erhielt während seiner langen Produktionszeit (34 Jahre), in der mehr als 473.000 Exemplare gebaut wurden, verschiedene Motoren : (1600 cm³, 1900cm³, 16PS, 11PS). Je nach Nutzen und Aufbau wechselte die Handelsbezeichnung, H (1200 kg Nutzlast), HZ (850 kg - 1000 kg), HY (1500 kg später 1600 kg, 1966), HP (Pritsche), HX (Kühlwagen) oder HW (Aufbaupritsche). Das letzte Exemplar verließ im Dezember 1981 mit der Fahrgestellnummer 473289, das Montageband. Die Garage ACIER befindet sich in der 128 Rue de Lille in Neuville Saint Rémy, vor den Toren von Cambrai (59). Sie entstand 1971 durch den Kauf einer PANHARD-Garage durch das Ehepaar Acier. Von einem Familienbetrieb mit einem Mitarbeiter, ist es heute eine GmbH mit 6 Mitarbeitern und einem Lehrling geworden.

Español

Se trata de una furgoneta que puede cargar 1200 kg de mercancías en un volumen de 7,3 m³. Fue diseñado por Pierre Franchiset, de quien toma su nombre, la «H» se debe a que es el octavo proyecto de este tipo desarrollado por Citroën (la H es la octava letra del alfabeto). Su diseño es sencillo y se tarda muchos otros vehículos de los elementos de la marca: el motor y la caja de cambios del Traction, conducir, metro, 2CV limpiaparabrisas. Fue presentado al público en 1947 y recibió diferentes del motor (1600 cm³, 1900cm³, 16cv, 11HP) durante su larga carrera (34 años), en el que se produjeron más de 473.000 copias. En función de la carga y su cuerpo, nombre comercial cambiante, H (1200 kg de carga útil) HZ (850 kg - 1000 kg), HY (1500 kg y 1600 kg, 1966), HP (meseta), HX (estantería refrigerada) o HW (bandeja culturista). El último ejemplar salió de la línea de montaje en diciembre de 1981 (N ° 473289) Situado en el número 128 de la calle Lille en Neuville Saint Rémy, a las puertas de Cambrai (59), el taller ACIER fue creado en 1971 por la compra de un taller PANHARD por el Sr. y la Sra. Acier. De una empresa familiar con un empleado, es hoy una sociedad anónima con 6 empleados y un aprendiz.

Citroën Fourgon HY	
Longueur	4,26 m
Largeur	1,99 m
Hauteur	2,30 m
Voie av	1,62 m
Voie arr	1,66 m
Empattement	2,518 m
Moteur	4 cylindres, 1628 cm ³ , 1911 cm ³
Boite	vitesse à 3 rapports + arr
Traction avant	
Masse à vide	1500 kg
Charge utile	1200 kg (H), 850-1000 kg (HZ), 1500 kg (HY)

Citroën Fourgon HY	
Length	4,26 m
Width	1,99 m
Height	2,30 m
Front track	1,62 m
Rear track	1,66 m
Wheelbase	2,518 m
Motor	4 cylinder, 1628 cm ³ , 1911 cm ³
Gearbox	3 gears + reserve
Front wheel drive	
Unladen weight	1500 kg
Payload	1200 kg (H), 850-1000 kg (HZ), 1500 kg (HY)

Citroën Fourgon HY	
Länge	4,26 m
Breite	1,99 m
Höhe	2,30 m
Vordere Spur	1,62 m
Hintere Spur	1,66 m
Radstand	2,518 m
Motor	4 Zylinder, 1628 cm ³ , 1911 cm ³
Getriebe	3 Gängen + Rückwärtsgang
Vorderradantrieb	
Leergewicht	1500 kg
Nutzlast	1200 kg (H), 850-1000 kg (HZ), 1500 kg (HY)

Citroën Fourgon HY	
Longitud	4,26 m
Anchura	1,99 m
Altura	2,30 m
Via delantera	1,62 m
Via trasera	1,66 m
Distancia entre ejes	2,518 m
Motor	4 cilindros, 1628 cm ³ , 1911 cm ³
Caja	cambios con 3 marchas + tope
Tracción delantera	
Masa en vacío	1500 kg
Carga útil	1200 kg (H), 850-1000 kg (HZ), 1500 kg (HY)

Nederlands

Het is een bestelwagen die 1200 kg goederen kan laden in een volume van 7,3 m³. Het is ontworpen door Pierre Franchiset aan wie hij zijn naam te danken heeft, de „H”, omdat het het achtste project van dit type is dat is ontwikkeld door Citroen, waarbij de H de achtste letter van het alfabet is. Het ontwerp was eenvoudig en het gebruikte veel elementen van andere Citroëns: motor en versnellingsbak van de Traction, stuurwiel, snelheidsmeter en ruitenwissers van de 2CV. Hij werd in 1947 aan het publiek voorgesteld en kreeg verschillende motoren gedurende zijn lange productieperiode (34 jaar), gedurende welke meer dan 473.000 exemplaren werden gebouwd: (1600 cm³, 1900cm³, 16hp, 11hp). Afhankelijk van het gebruik en de constructie veranderde de handelsbenaming, H (1200 kg laadvermogen), HZ (850 kg - 1000 kg), HY (1500 kg later 1600 kg, 1966), HP (platform), HX (koelwagen) of HW (bovenbouwplatform). Het laatste exemplaar verliet de assemblage lijn in december 1981 met chassisnummer 473289. Gelegen op 128 Rue de Lille in Neuville Saint Rémy, aan de poorten van Cambrai (59), werd de garage ACIER in 1971 opgericht door de aankoop van een garage PANTHARD door de heer en mevrouw Acier. Van een familiebedrijf met één werknemer, is het vandaag een LLC met 6 werknemers en een leerling.

Italiano

È un autocarro che può caricare fino a 1200 kg di merci in un volume di 7,3 m³. È stato progettato da Pierre Franchiset a cui deve il proprio nome, l'“H”, perché si tratta dell'ottavo progetto di questo tipo sviluppato da Citroen, e la H è l'ottava lettera dell'alfabeto. Il suo design è semplice e prende molti altri veicoli del marchio elementi: il motore e il cambio della trazione, unità, metro, tergicristallo 2CV. Fu presentato al pubblico nel 1947 e ricevette diversi motori (1600 cm³, 1900cm³, 16hp, 11HP) durante la sua lunga carriera (34 anni), in cui furono prodotti più di 473.000 esemplari. A seconda del carico e del suo corpo, il nome commerciale è cambiato, H (1200 kg di carico utile) HZ (850 kg - 1000 kg), HY (1500 kg e 1600 kg, 1966), HP (plateau), HX (rack refrigerato) o HW (vassoio per carrozzieri). L'ultimo uscì dalla catena di montaggio nel dicembre 1981 (n. 473289). Situata al 128 di Rue de Lille a Neuville Saint Rémy, alle porte di Cambrai (59), l'officina ACIER è stata creata nel 1971 dall'acquisto di un'officina PANTHARD dai signori Acier. Da un'impresa familiare con un dipendente, è oggi una SRL con 6 dipendenti e un apprendista.

Citroën Fourgon HY	
Lengte	4,26 m
Breedte	1,99 m
Hoogte	2,30 m
Voorste spoor	1,62 m
Spoor achteraan	1,66 m
Wielbasis	2,518 m
Motor	4 cilinder, 1628 cm ³ , 1911 cm ³
Versnellingsbak	3 versnellingen + stop
Voorwielaandrijving	
Leeggewicht	1500 kg
Laadvermogen	1200 kg (H), 850-1000 kg (HZ), 1500 kg (HY)

Citroën Fourgon HY	
Lunghezza	4,26 m
Larghezza	1,99 m
Altezza	2,30 m
Pista anteriore	1,62 m
Pista posteriore	1,66 m
Passo	2,518 m
Motore	4 cilindri, 1628 cm ³ , 1911 cm ³
Cambio	3 marce + stop
Trazione anteriore	
Massa a vuoto	1500 kg
Carico utile	1200 kg (H), 850-1000 kg (HZ), 1500 kg (HY)

1/24

CITROËN HY 1957/1964

80744

PEINTURES ESSENTIELLE/ESSENTIAL PAINTS



3

Vert Brunswick brillant
Gloss Brunswick green
Glänzend-Dunkelgrün



9

Marron clair brillant
Gloss Tan
Glänzend-Holzbraun



11

Argent
Silver
Silber



14

Bleu de France brillant
Gloss french blue
Glänzend -Französischblau



20

Bordeaux brillant
Gloss crimson
Glänzend-Karmesinrot



21

Noir brillant
Gloss black
Glänzend-Schwarz



22

Blanc brillant
Gloss white
Glänzend-Weiss



33

Noir mat
Matt black
Matt-Schwarz



53

Gris métallique
Gunmetal
Metallgrau



69

Jaune brillant
Gloss yellow
Glänzend-Gelb



85

Noir de charbon satiné
Satin coal black
Seidenmatt-Kohlenschwarz



321

Rouge transparent
Clear red
Durchsichtiges Rot



322

Orange transparent
Clear orange
Durchsichtiges Orange



M1

Brun jaune clair
Light buff
Helles Gelbbraun



+

+

+

9

22

69

2

Numéro de phase
Step number
Schrittnummer
Número de fase

56

Référence de couleur
Colour reference no
Farbangabe
Referencia de color

37

Numéro de pièce
Part number
Teilenummer
Número de pieza

6

Numéro de decal
Decal number
Nummer von Abziehbild
Número de calcomanía

- Si aucune teinte n'est spécifiée, peindre dans les couleurs de la version choisie. Se reporter aux pages 16 - 17 pour le détail du schéma de peinture.
- When no color is specified, paint the item with colors of chosen version. Refer to pages 16 - 17 for painting pattern.
- Wenn keine Farbe angegeben ist, Teile mit den Farben der gewählten Version bemalen. Beachten Sie die Seiten 16 - 17 für die Lackierung und Markierung.
- Cuando ningún color es especificado, pintarle con los colores del tema de la versión elegida. Vea las páginas 16 - 17 para obtener detalles de pintura.

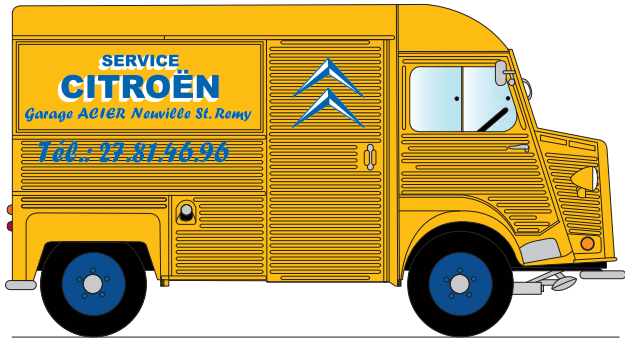

a • CITROËN HY, 1964

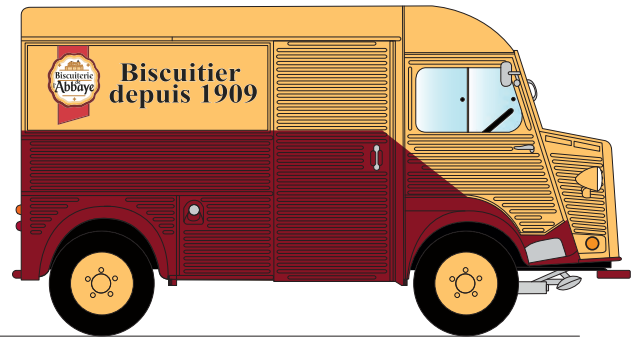

b • CITROËN HY, 1957

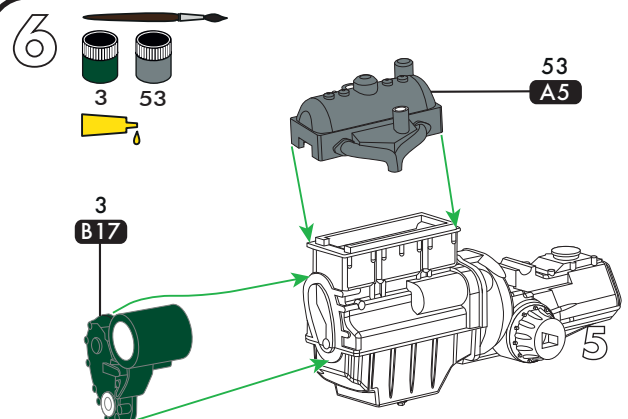
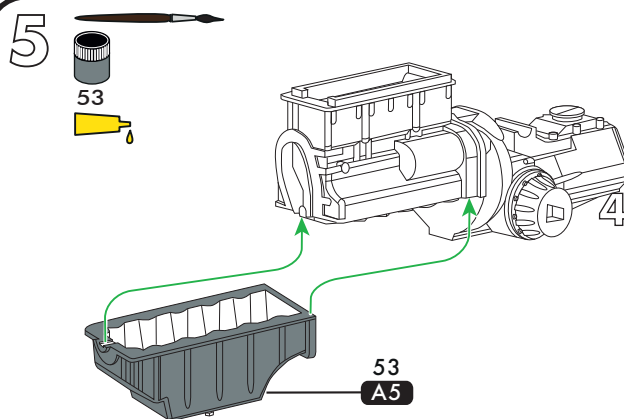
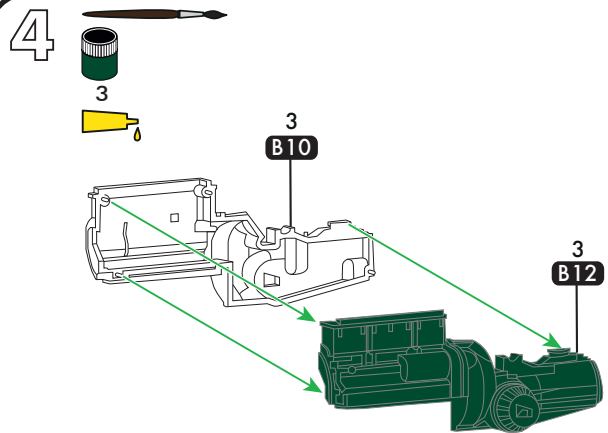
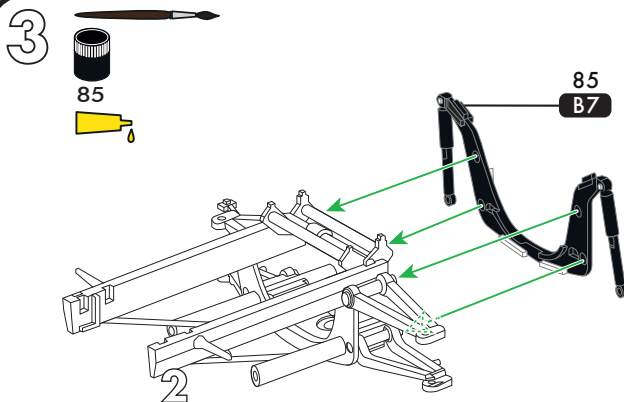
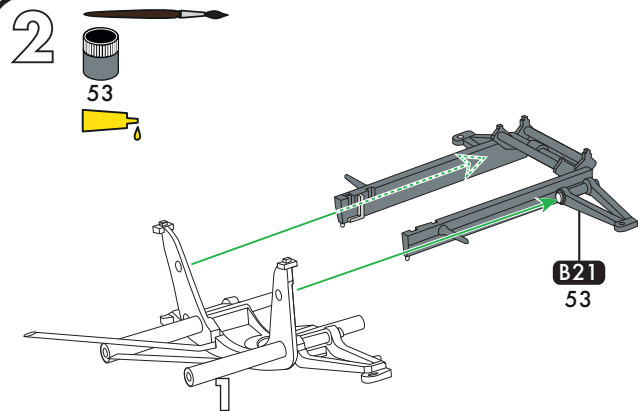
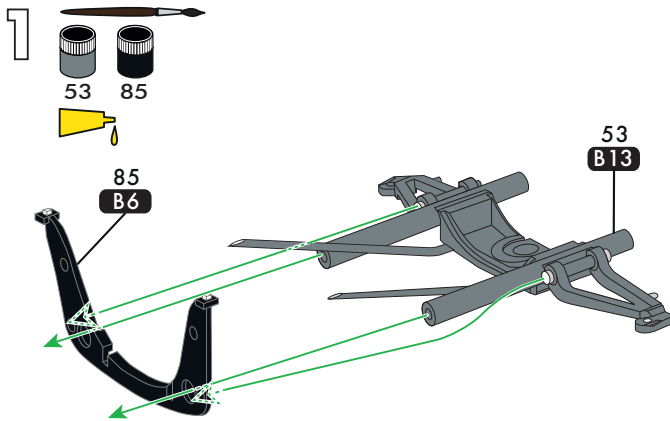

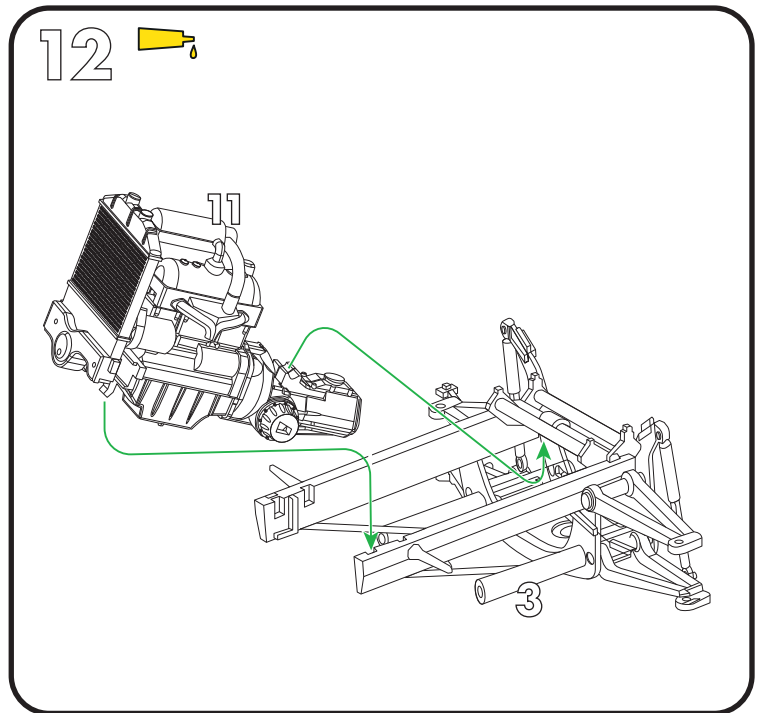
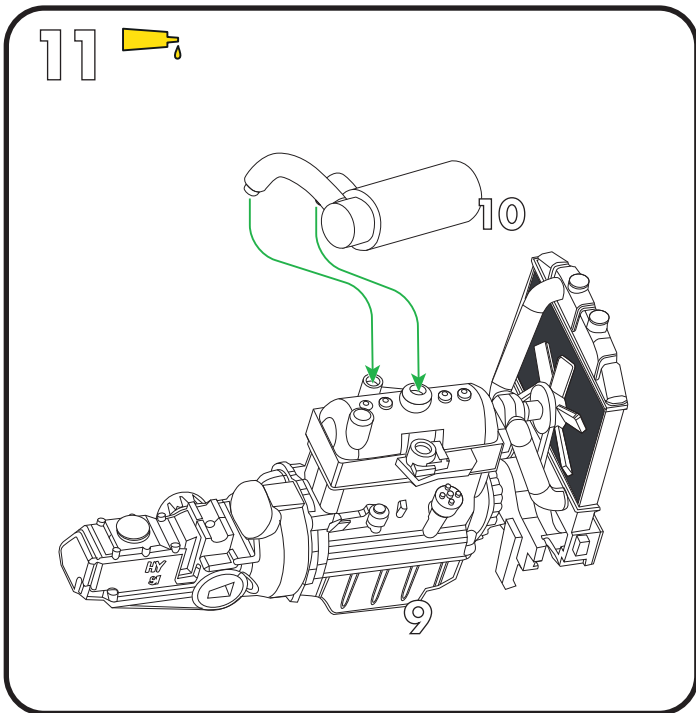
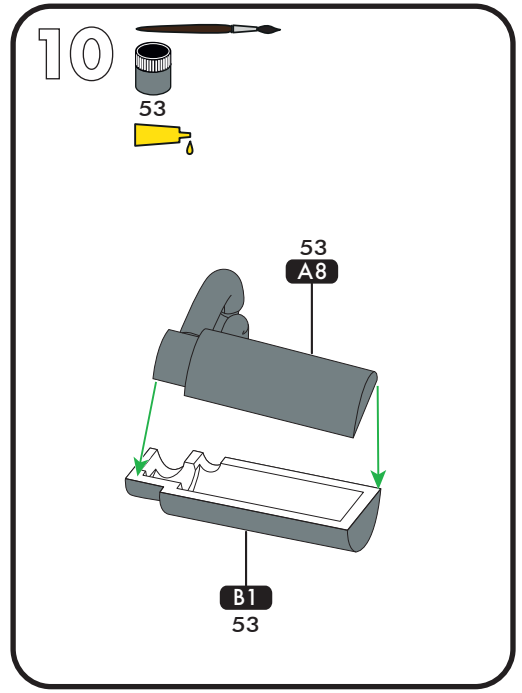
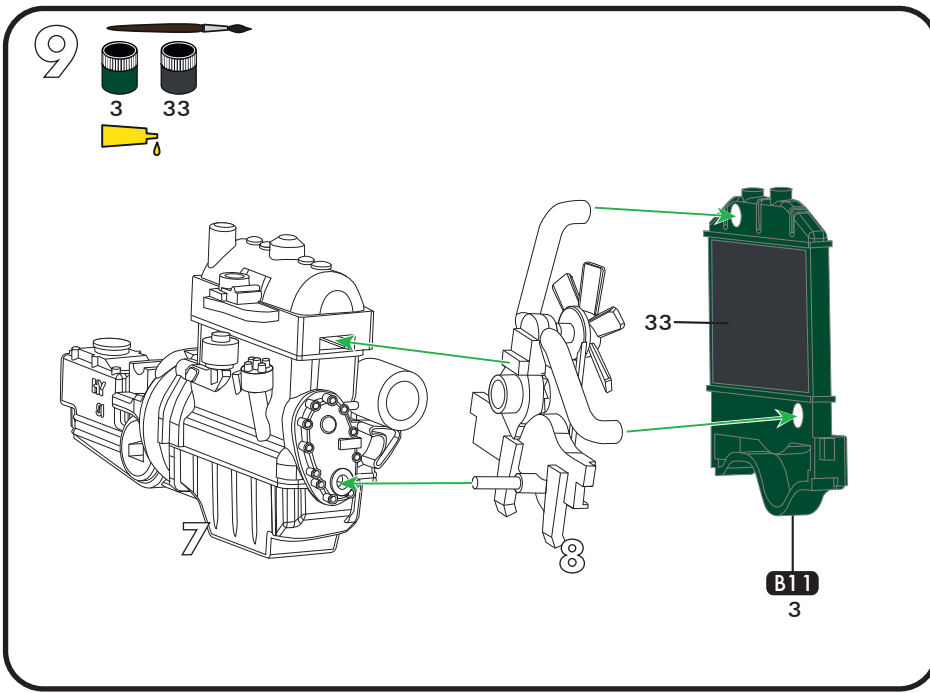
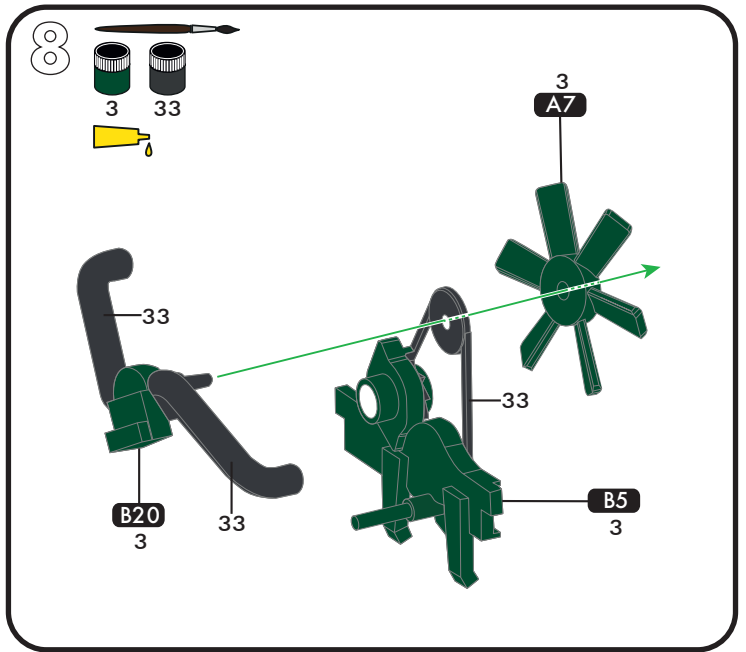
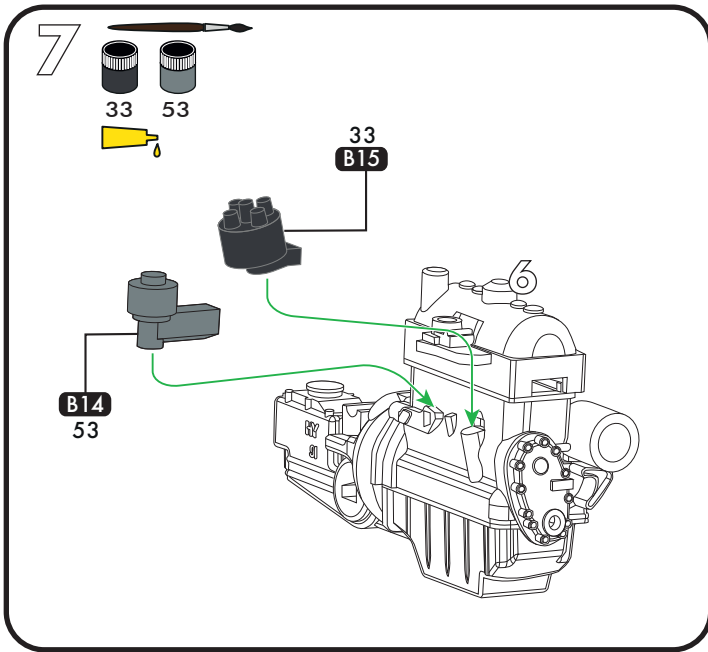

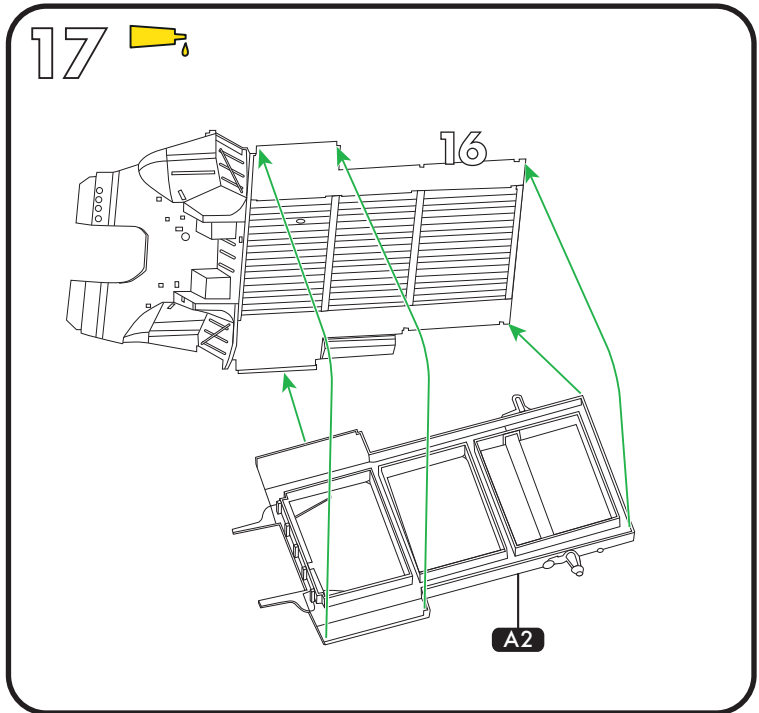
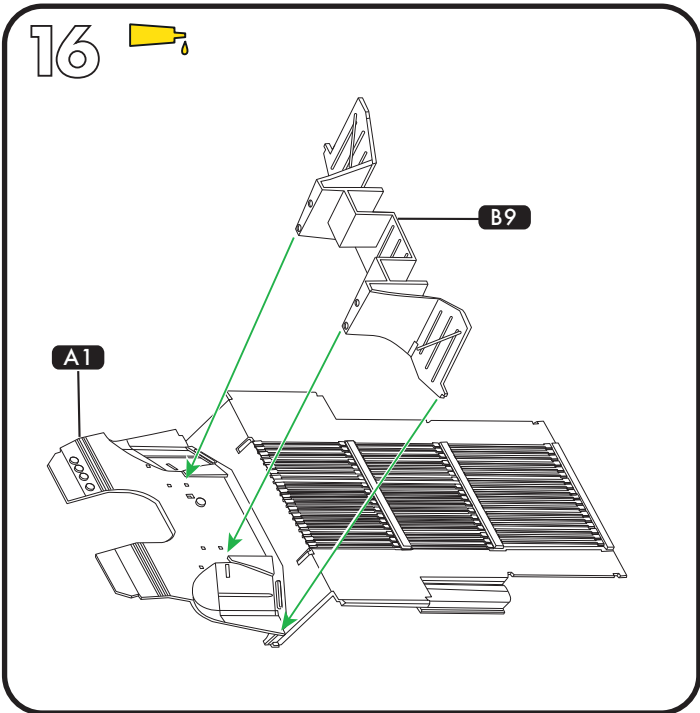
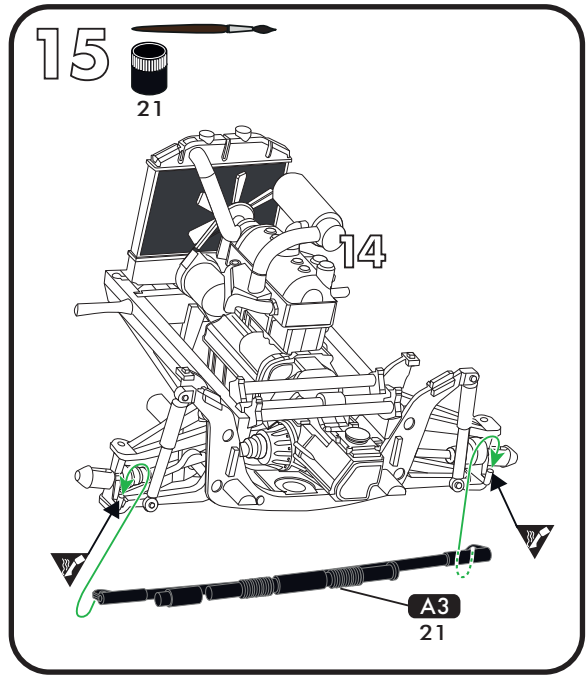
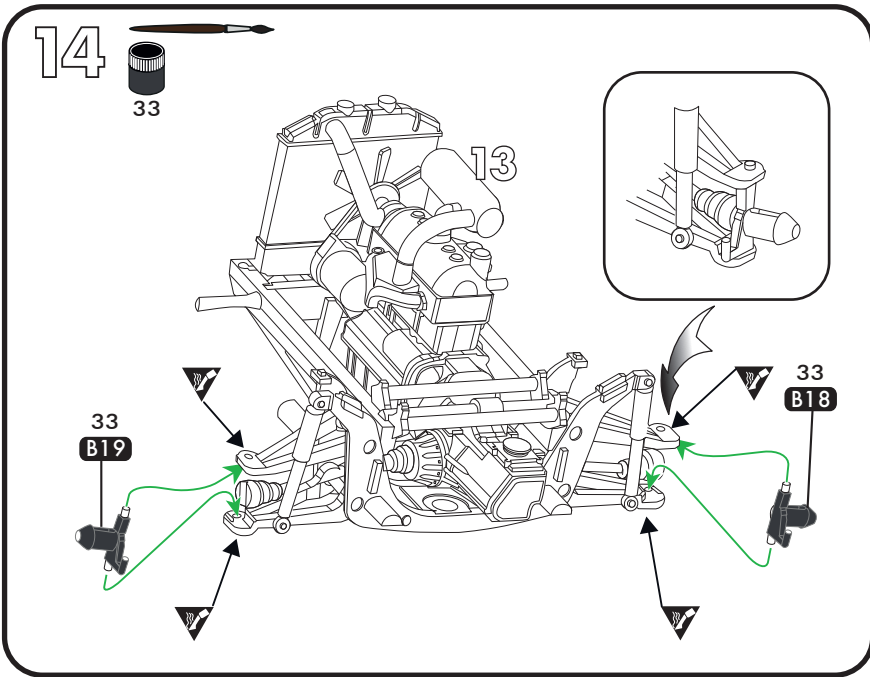
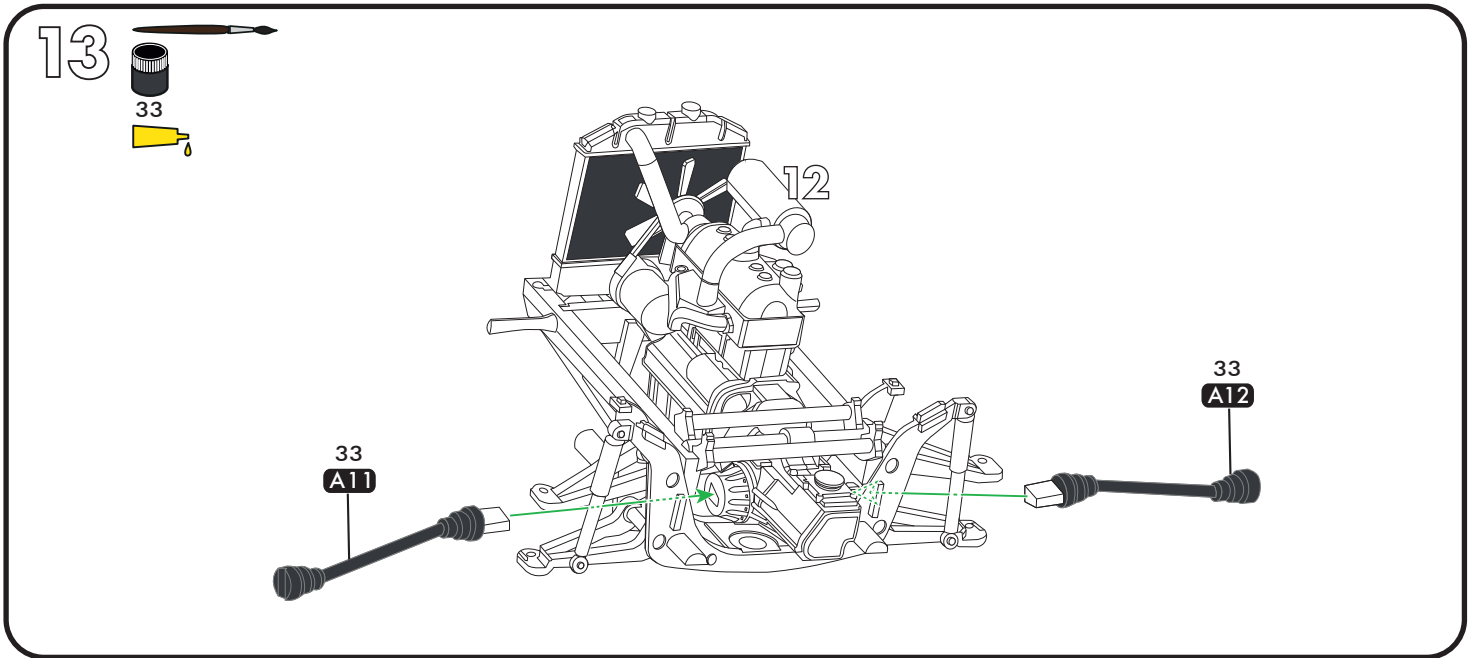

18

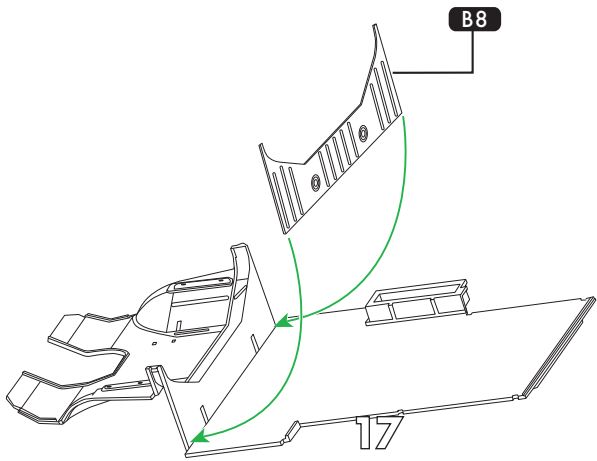

19

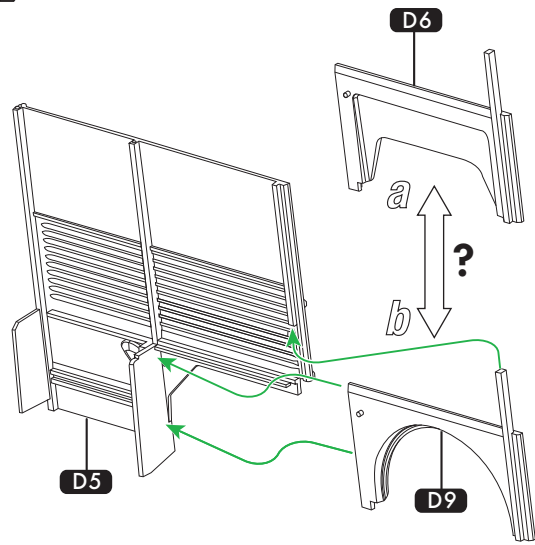

20

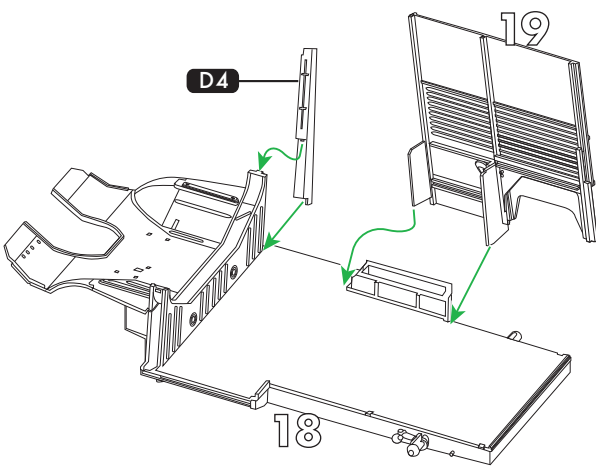

21

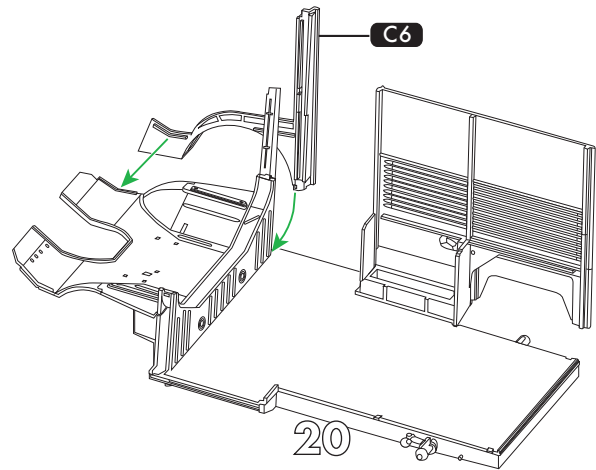

22

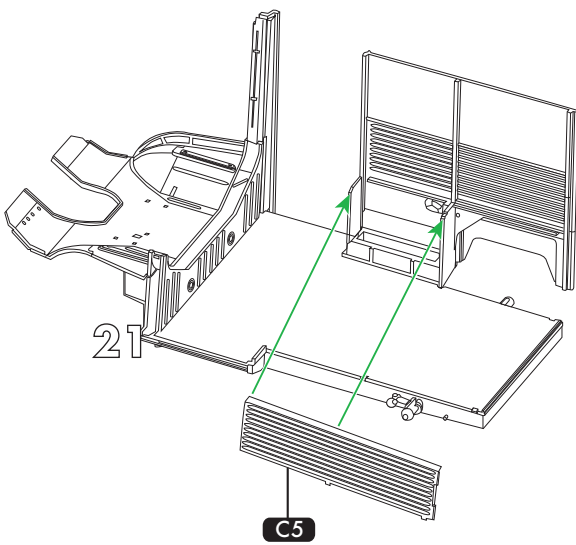

23

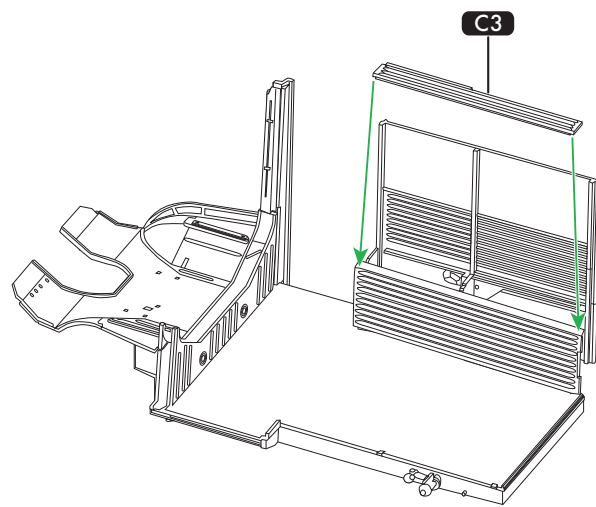

24

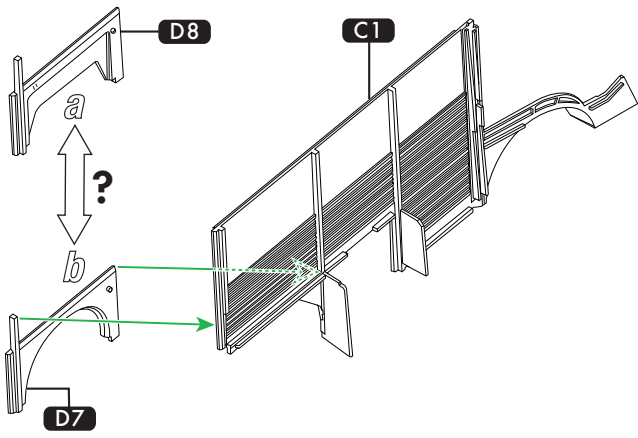

25

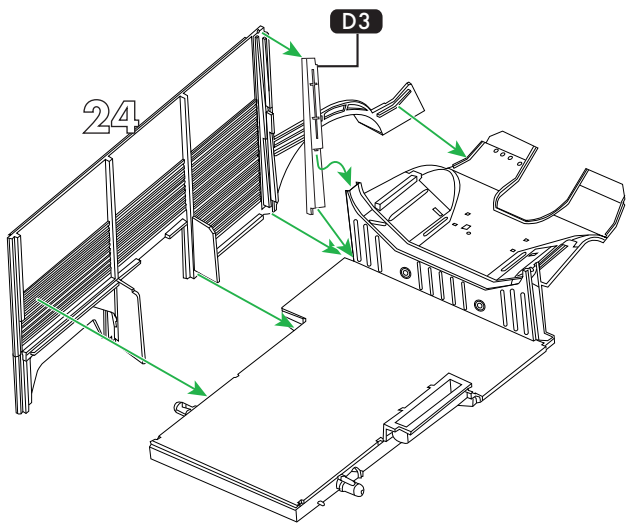

26

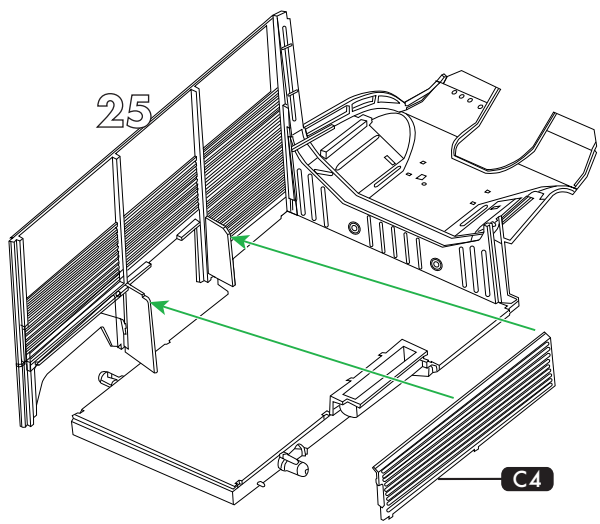

27



Peindre l'intérieur en concordance avec la décoration finale choisie.
Paint the interior consistent with the chosen final decoration.

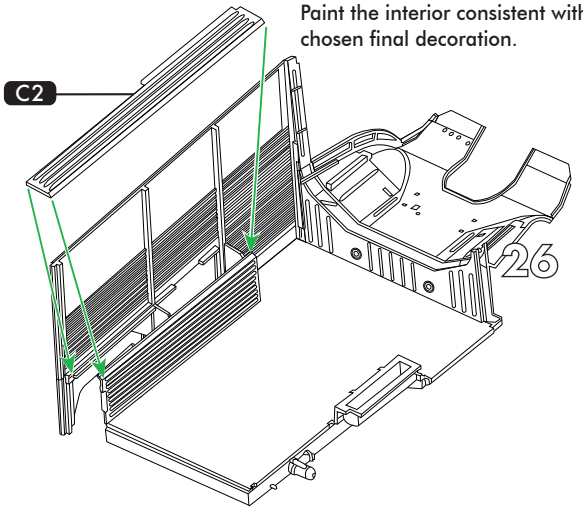

Pintar el interior en consonancia con la decoración final elegido. Bemalen Sie das Innere mit den Farben der gewählten Version.

28



33

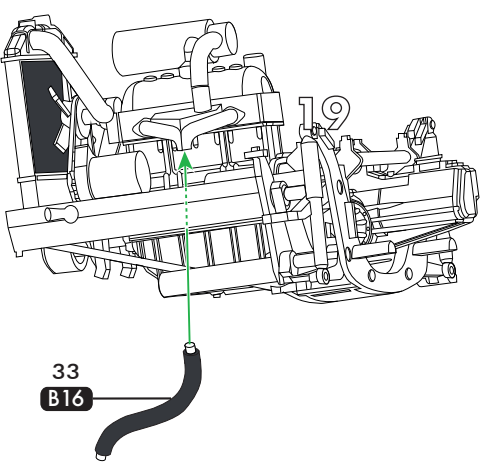

29



53

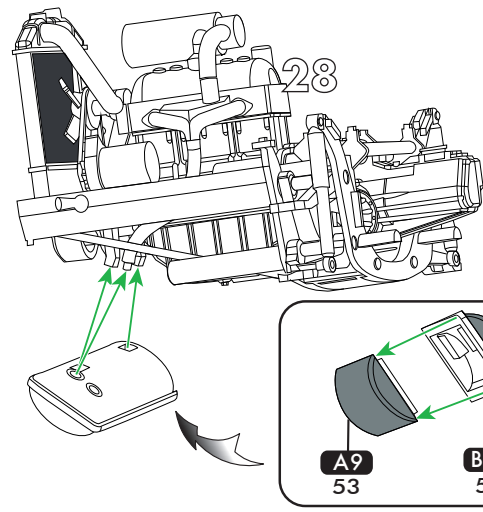

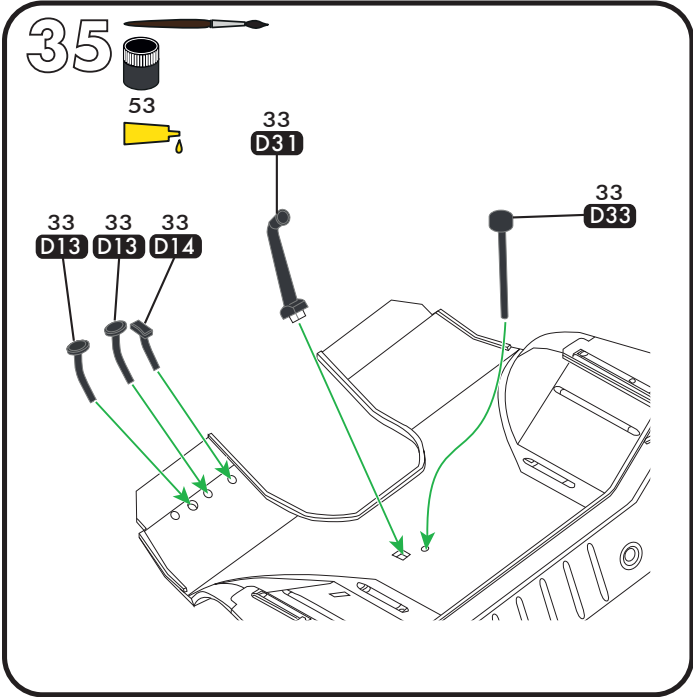
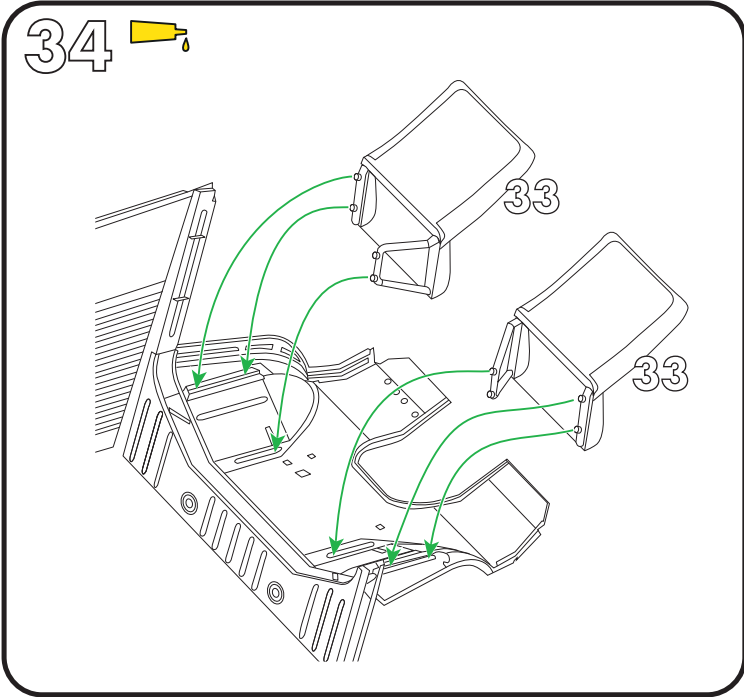
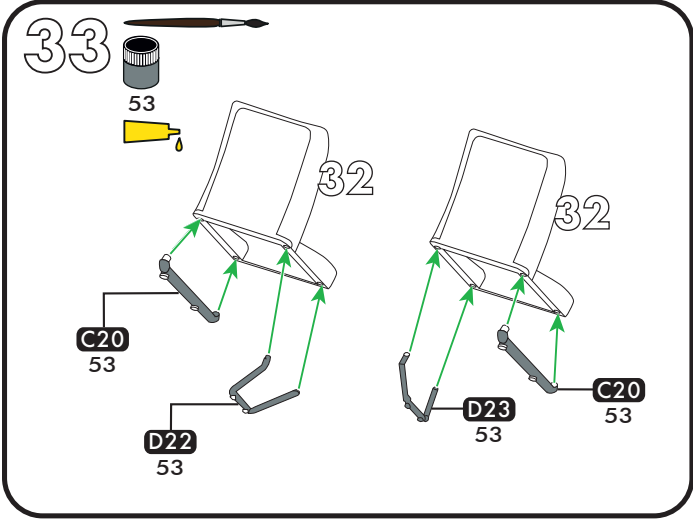
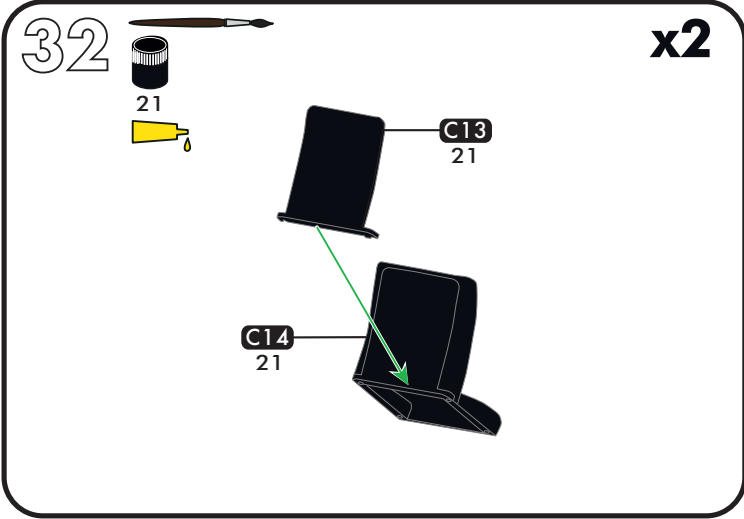
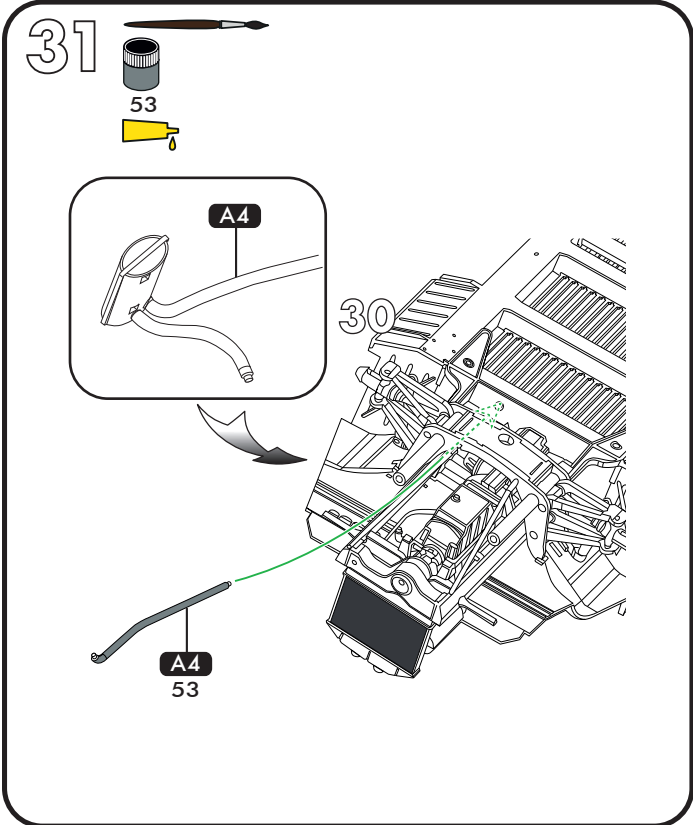
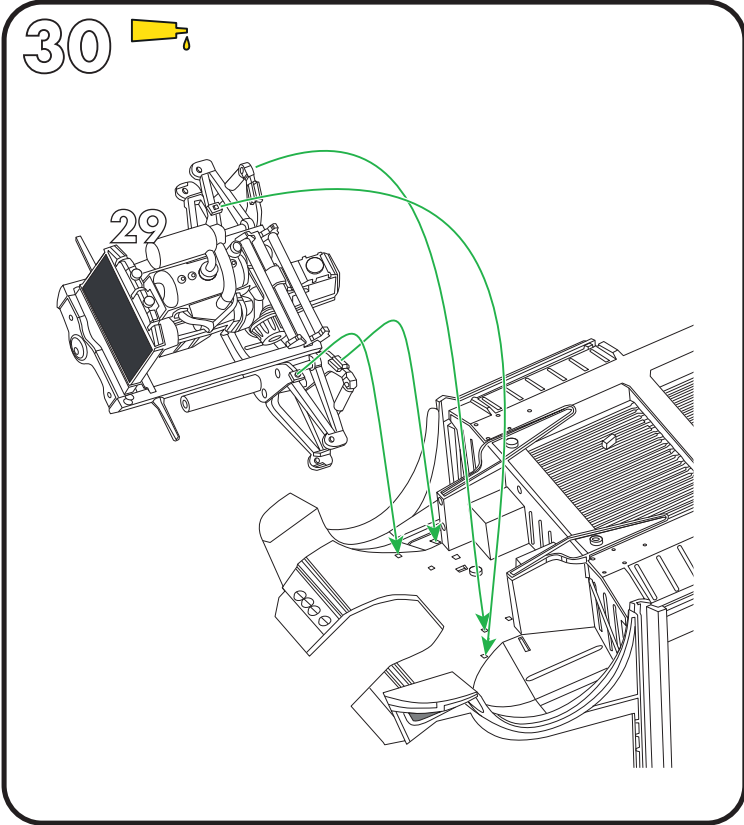

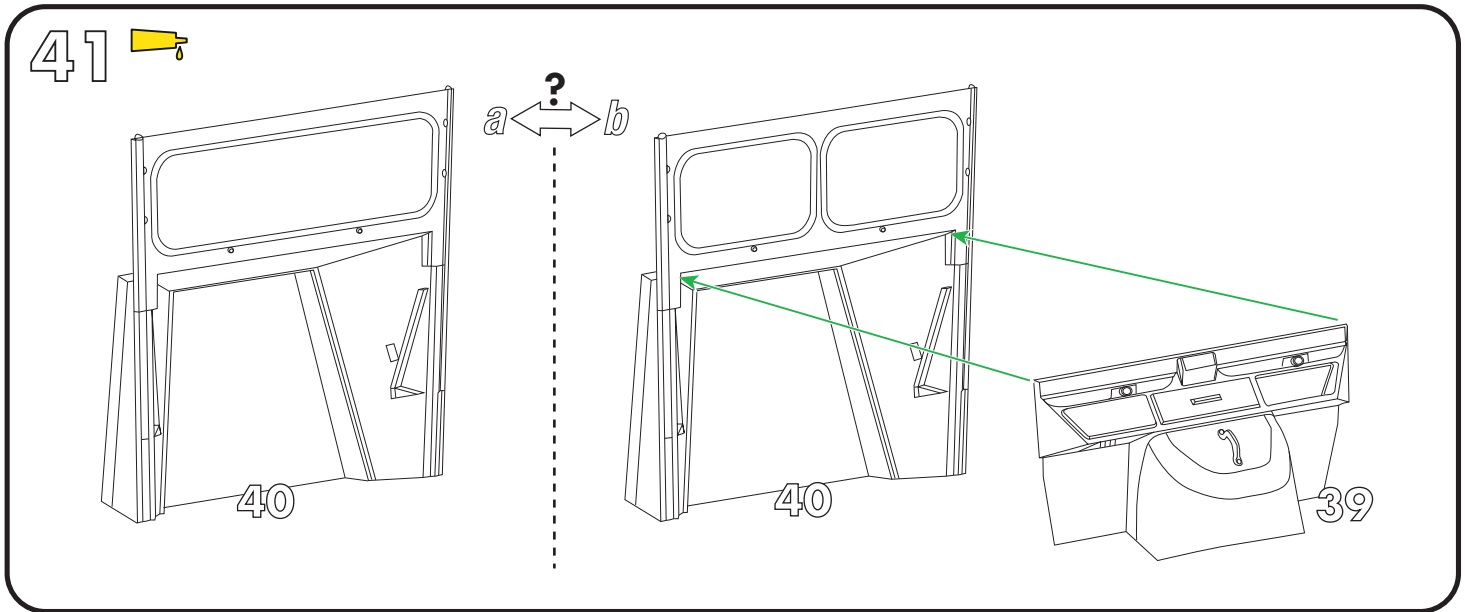
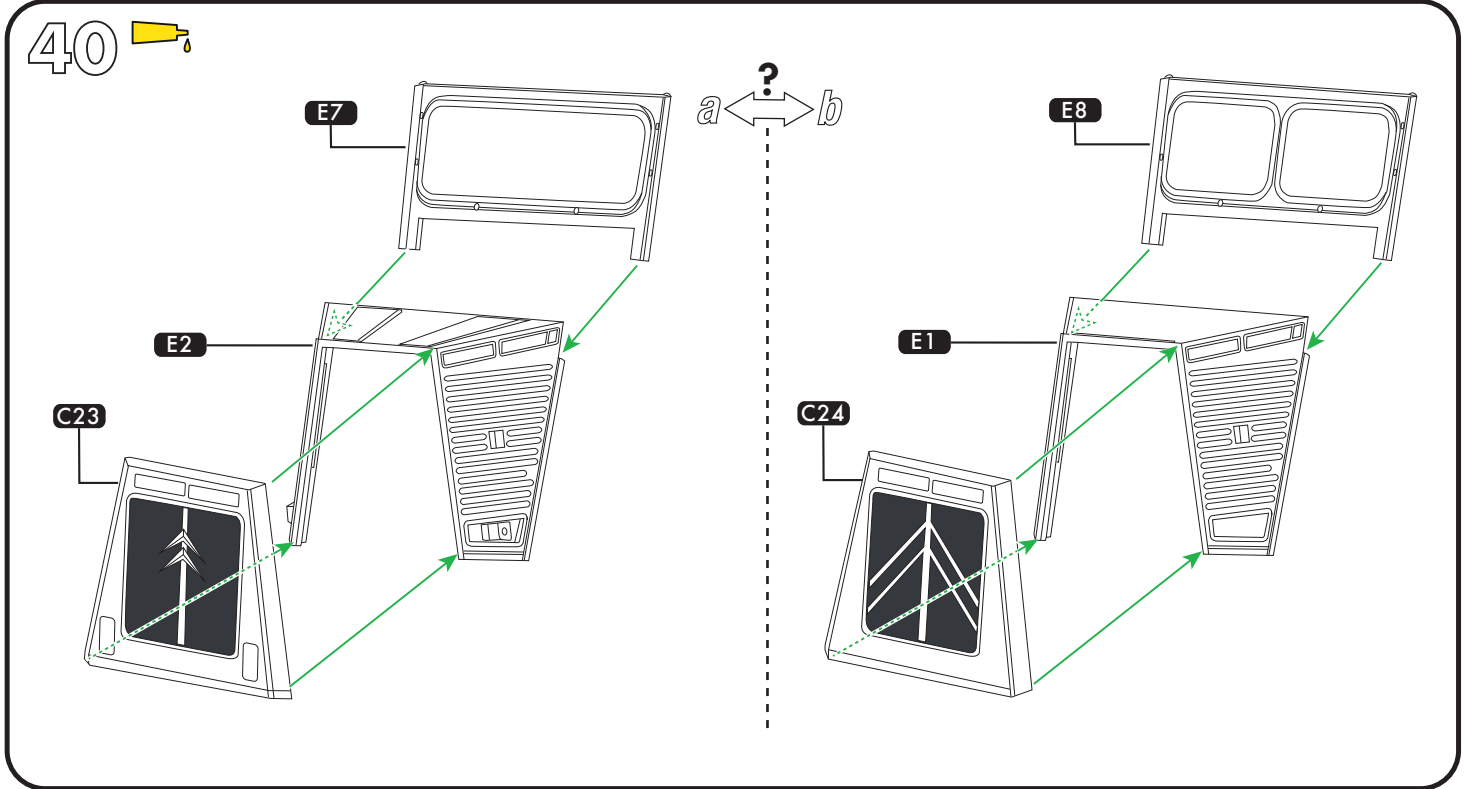
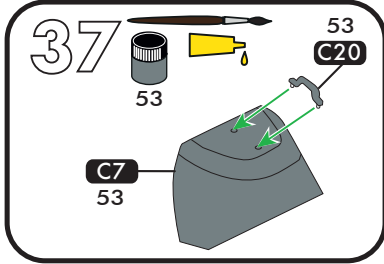
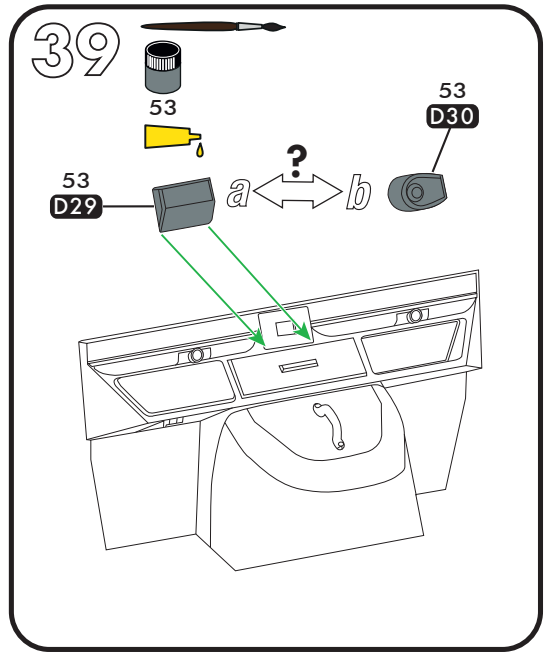
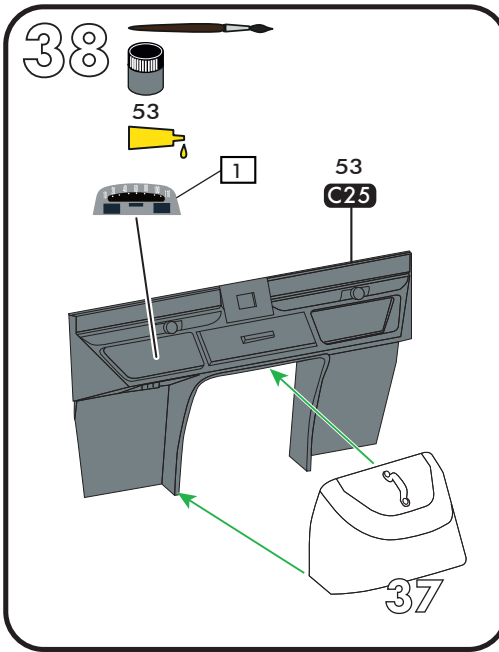
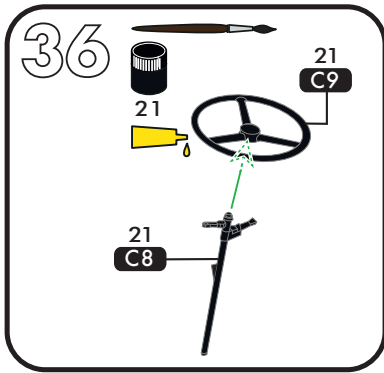

42 

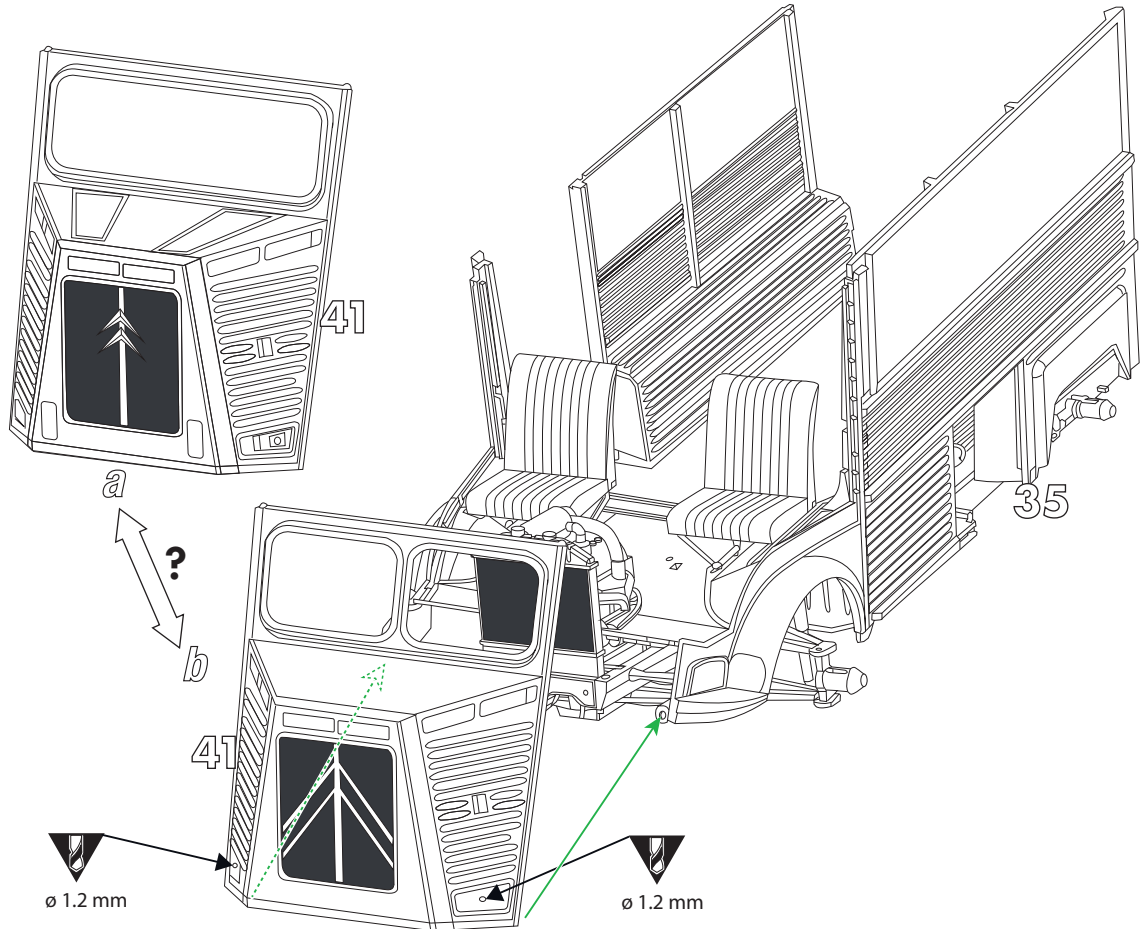

43 

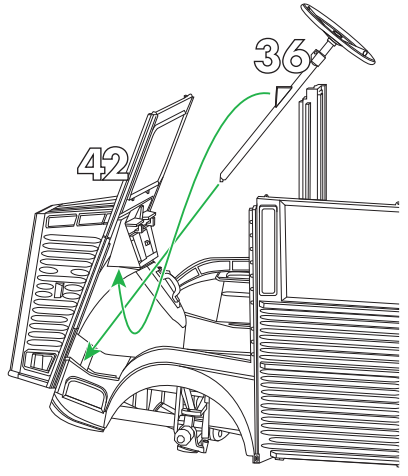

44 

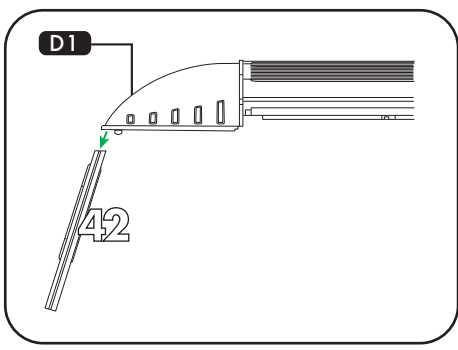
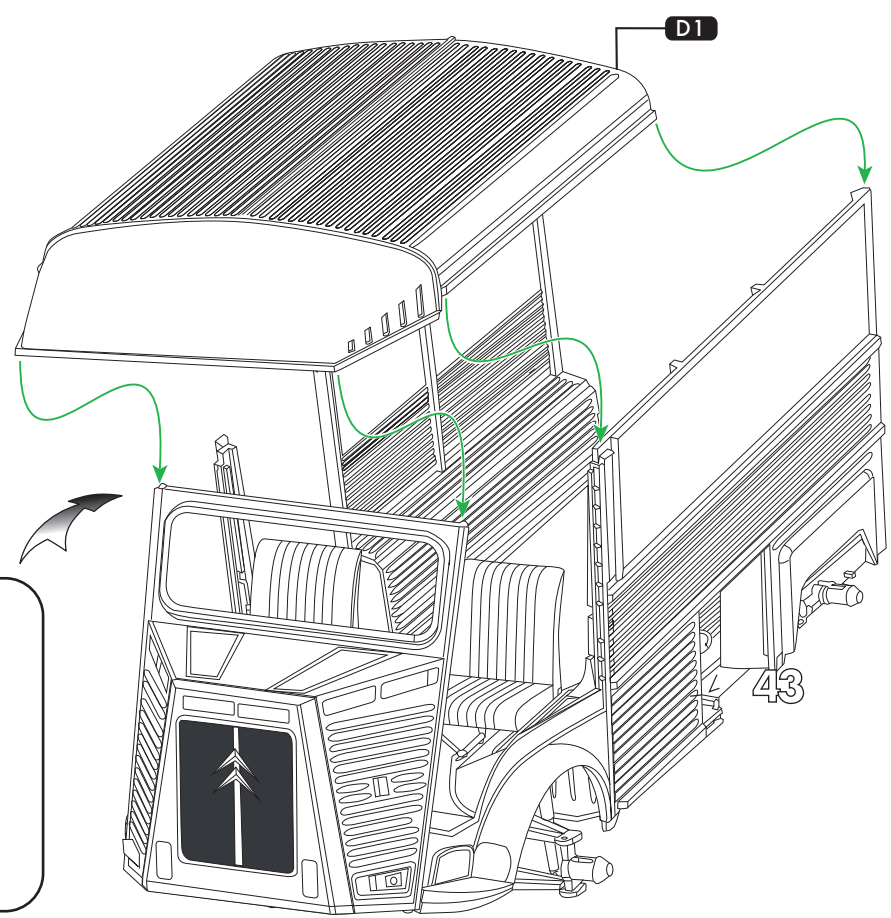

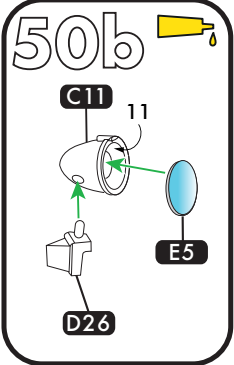
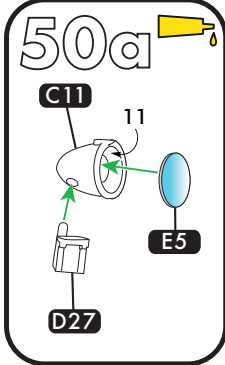
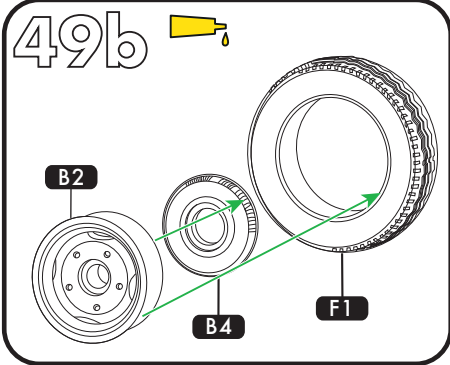
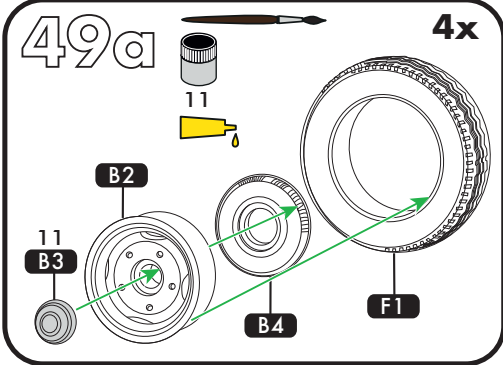
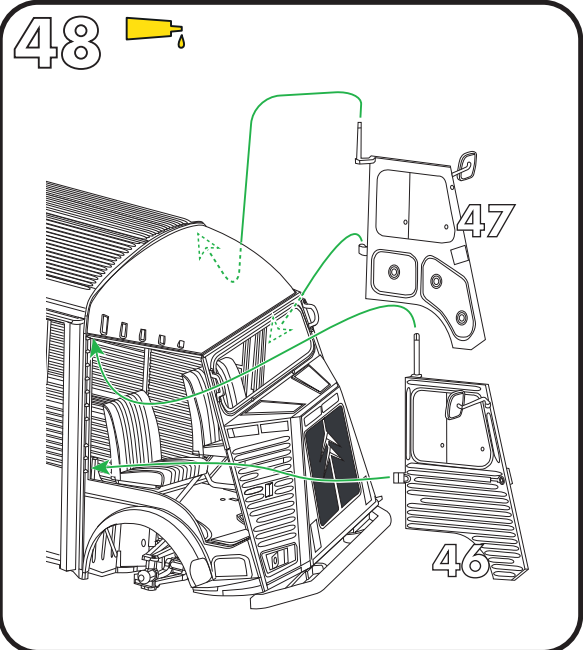
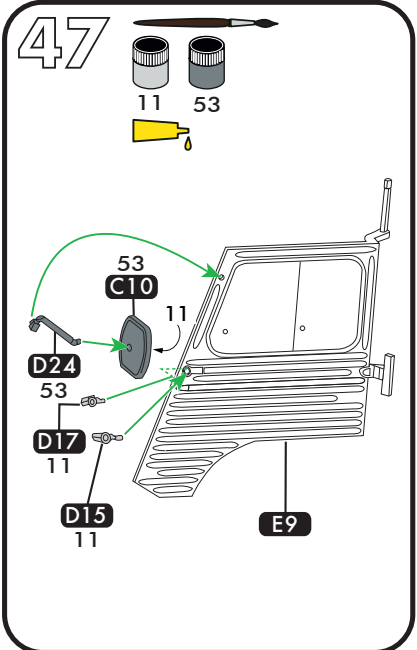
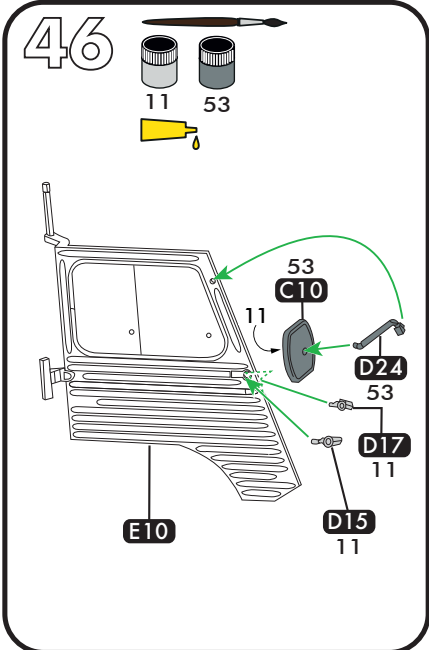
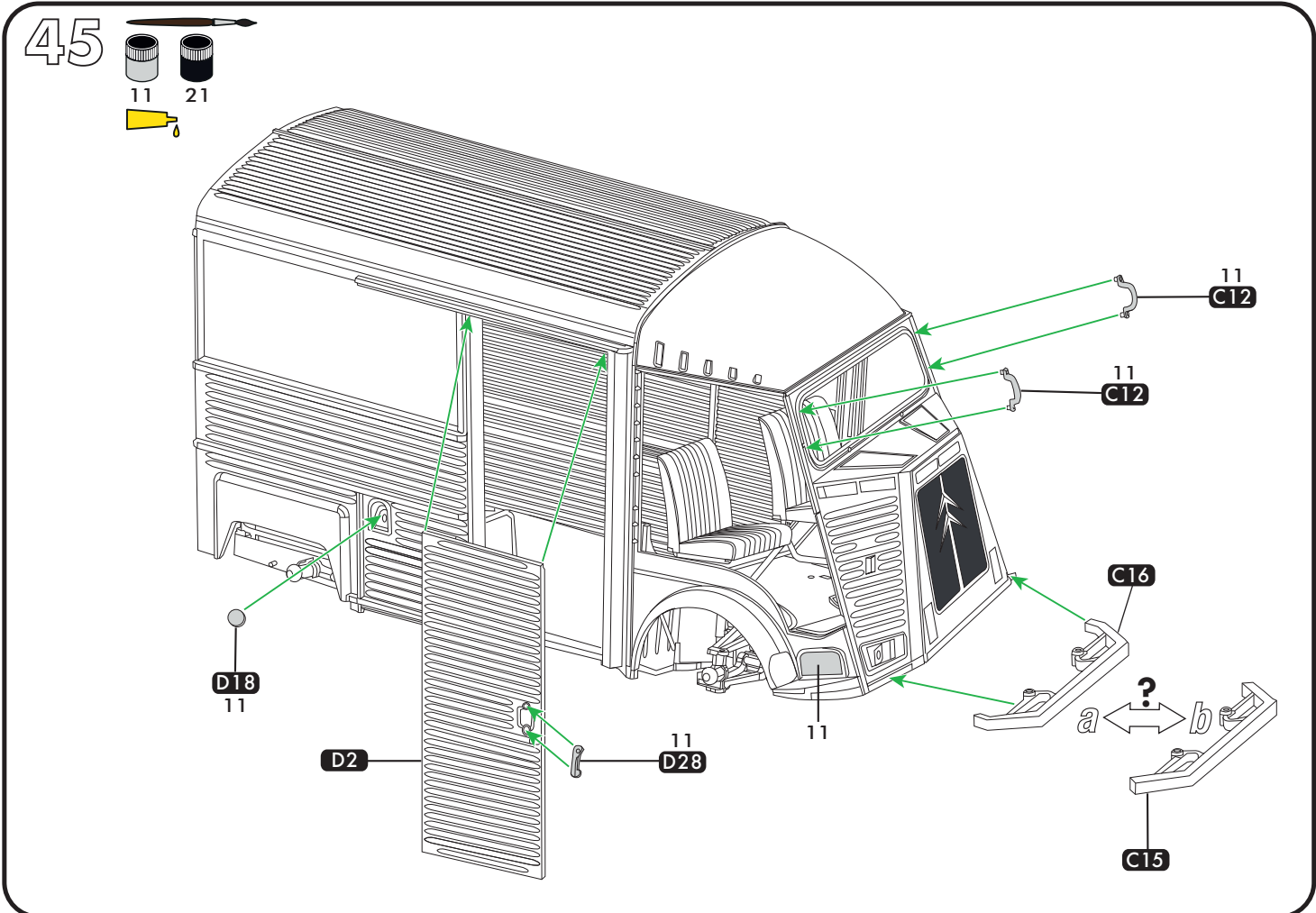

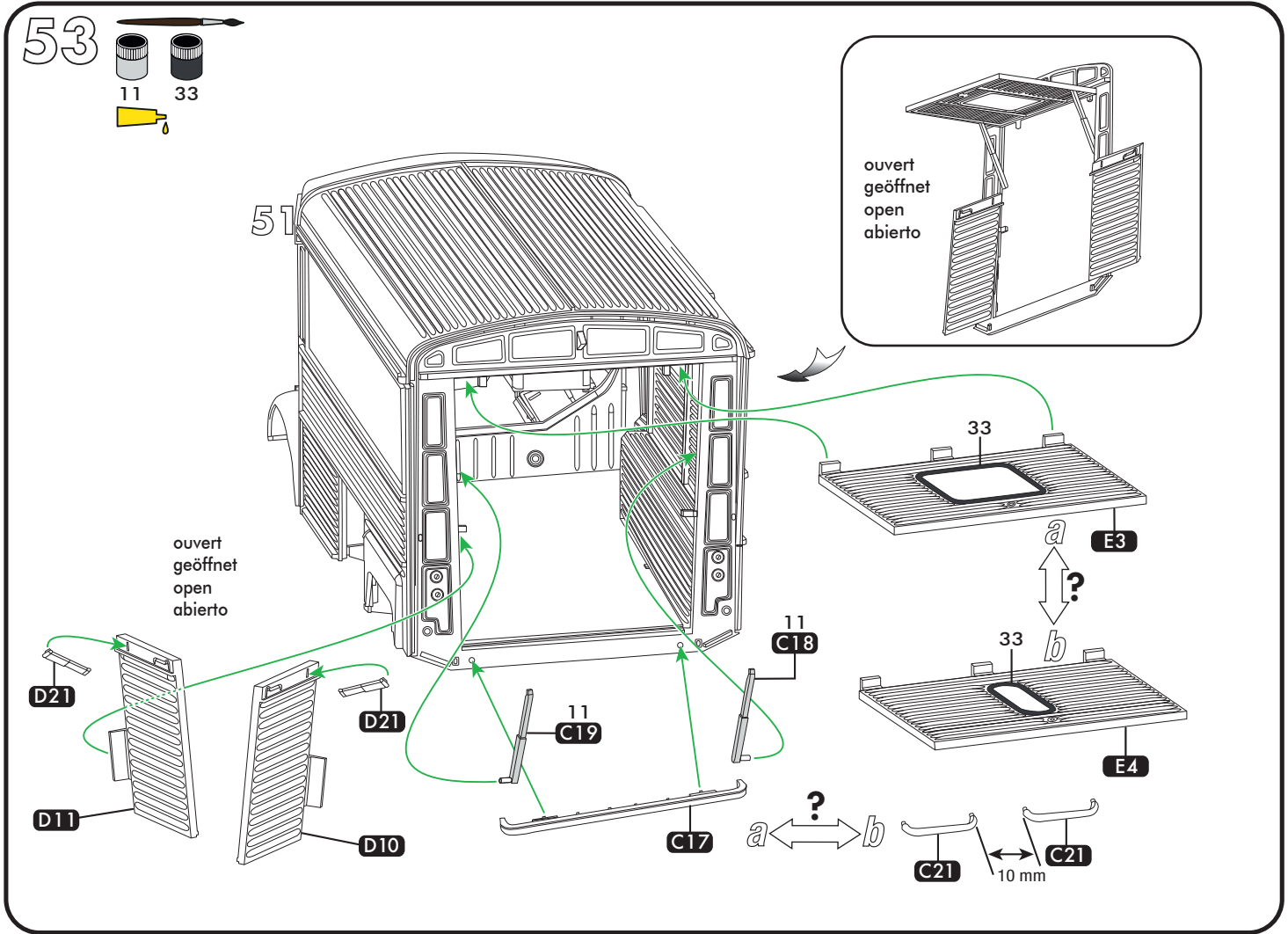
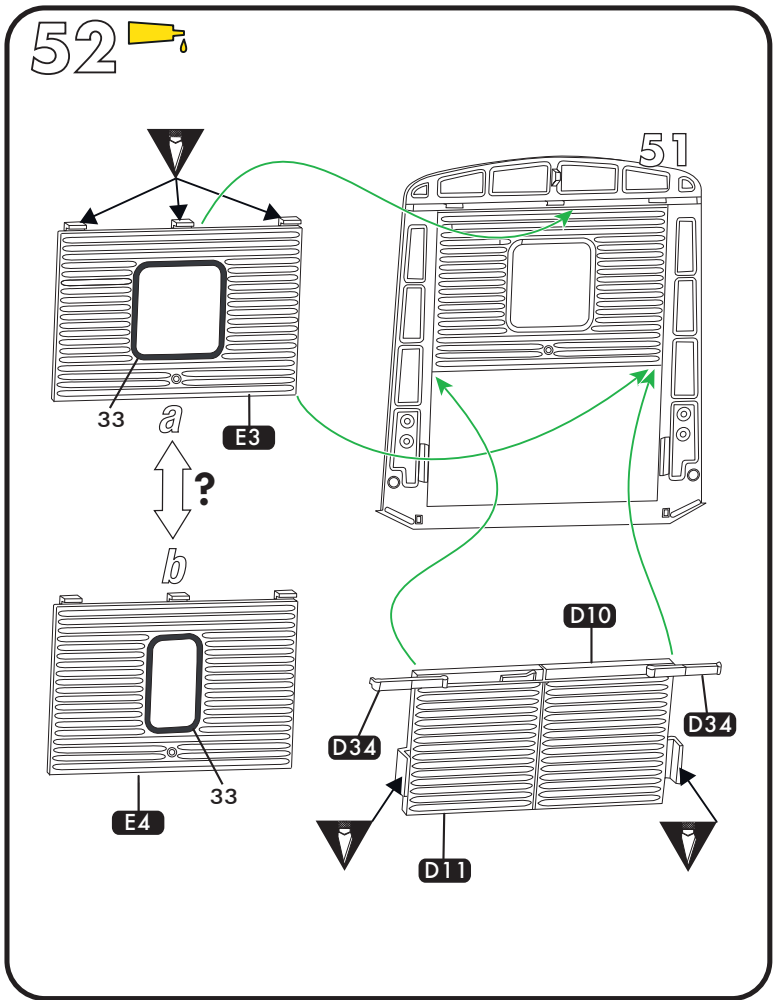
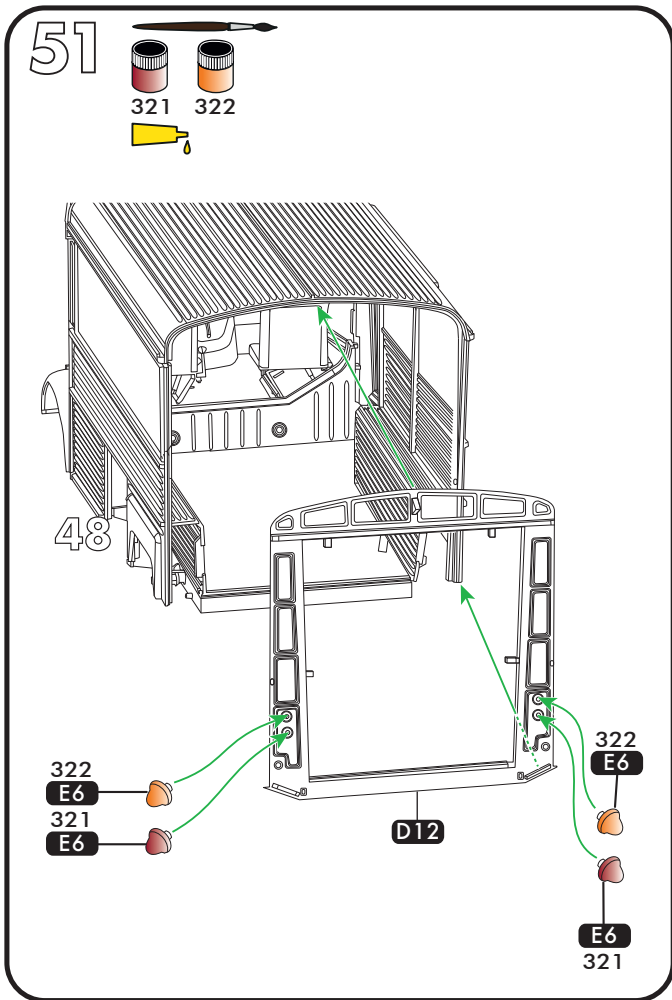

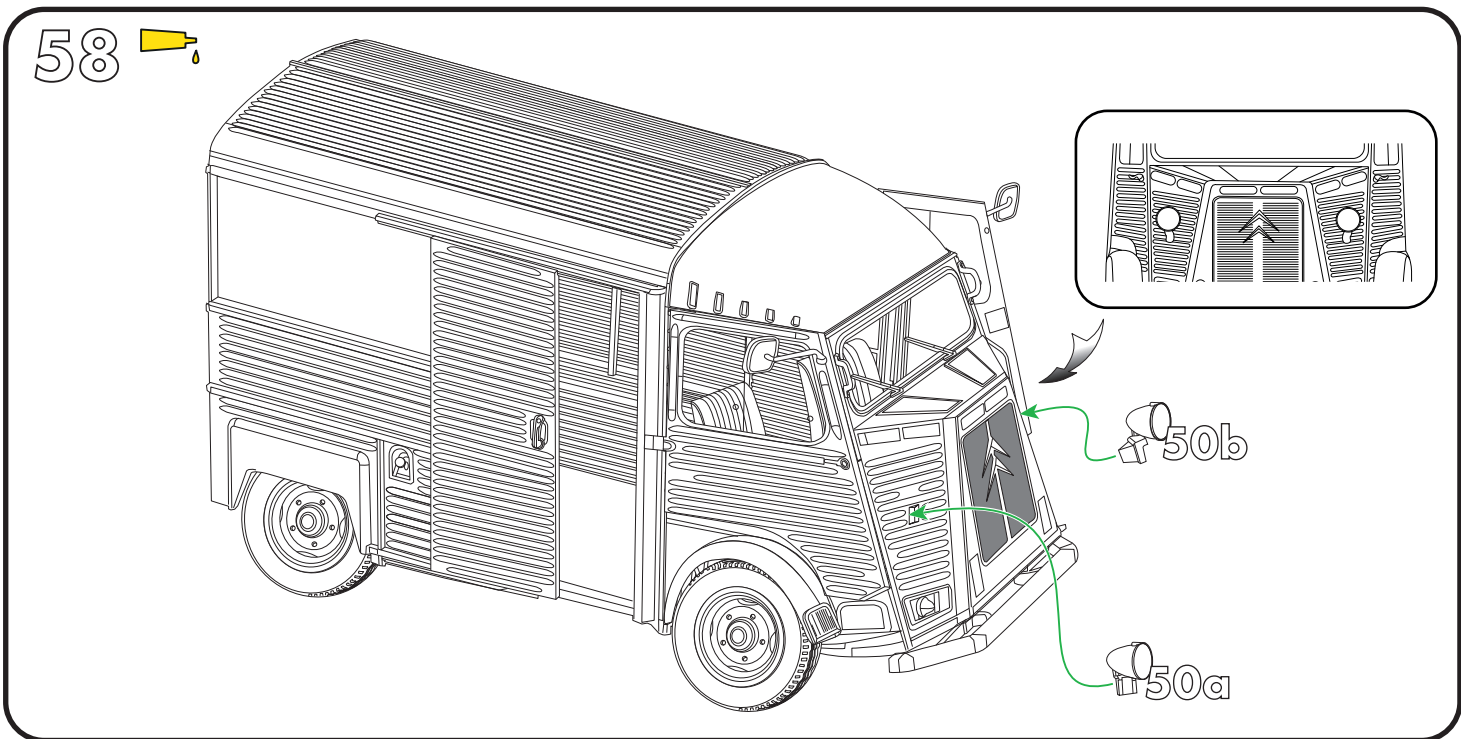
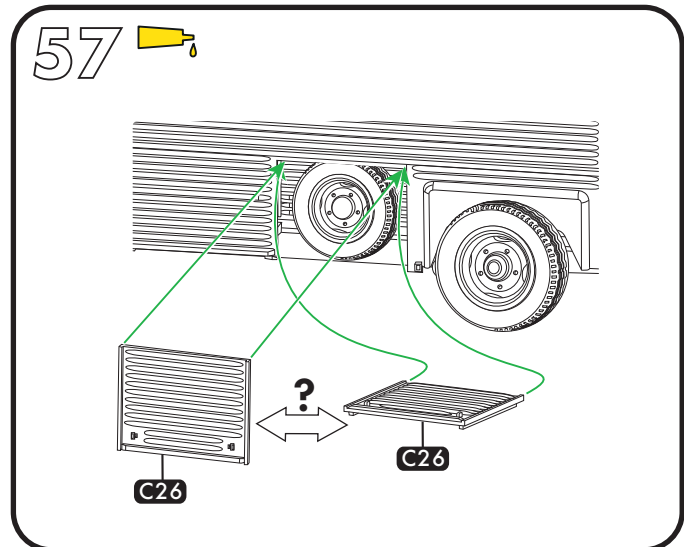
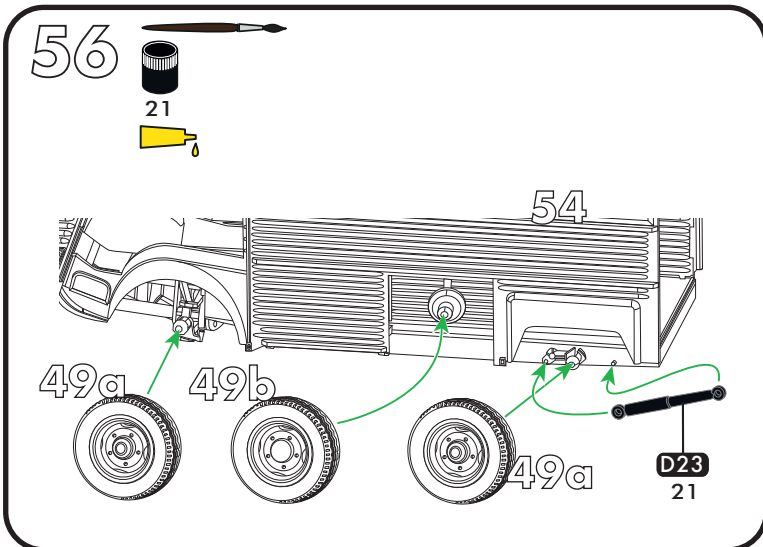
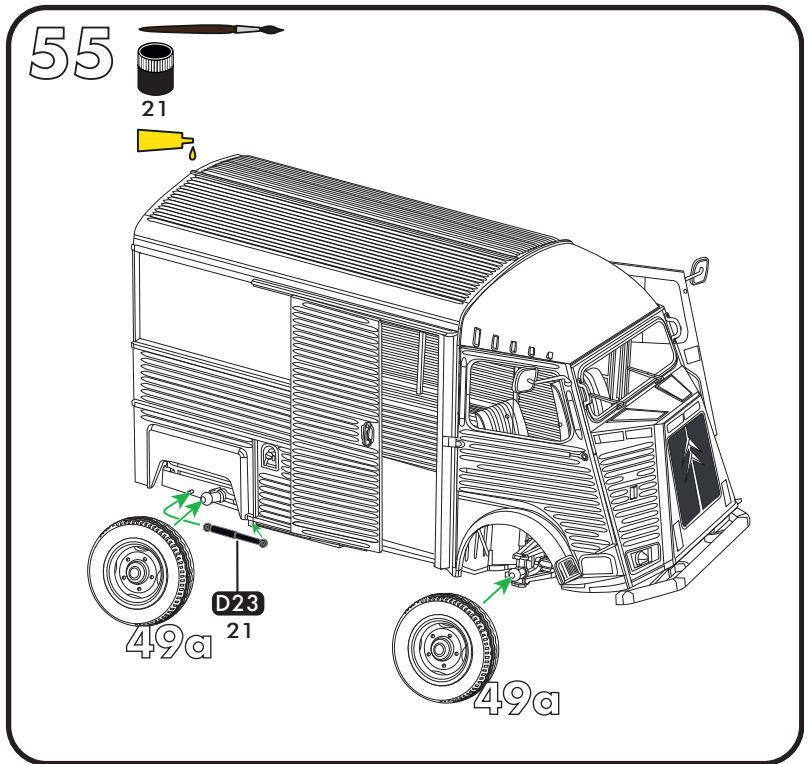
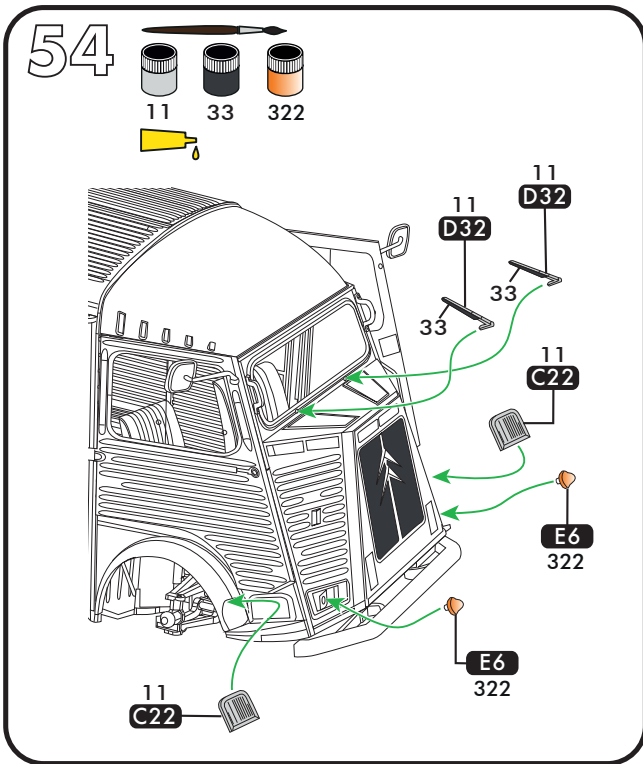

59

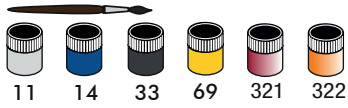

a • CITROËN HY, 1964

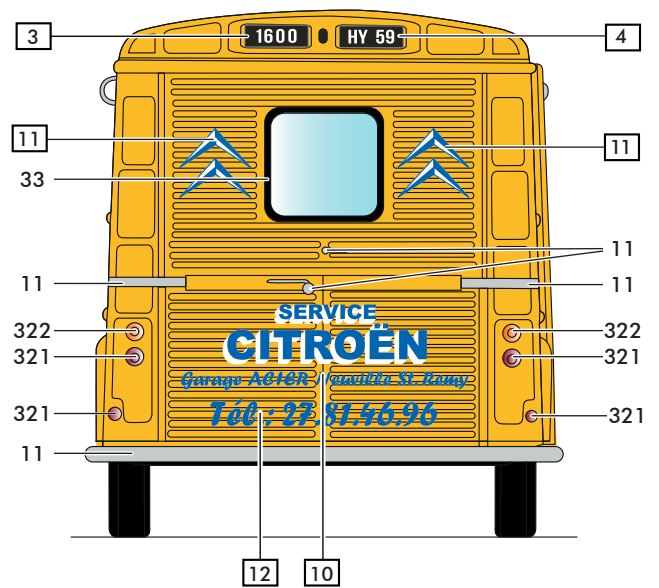
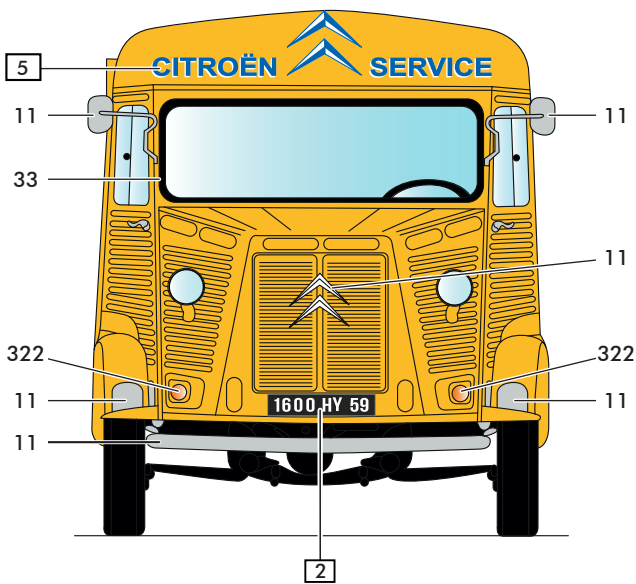
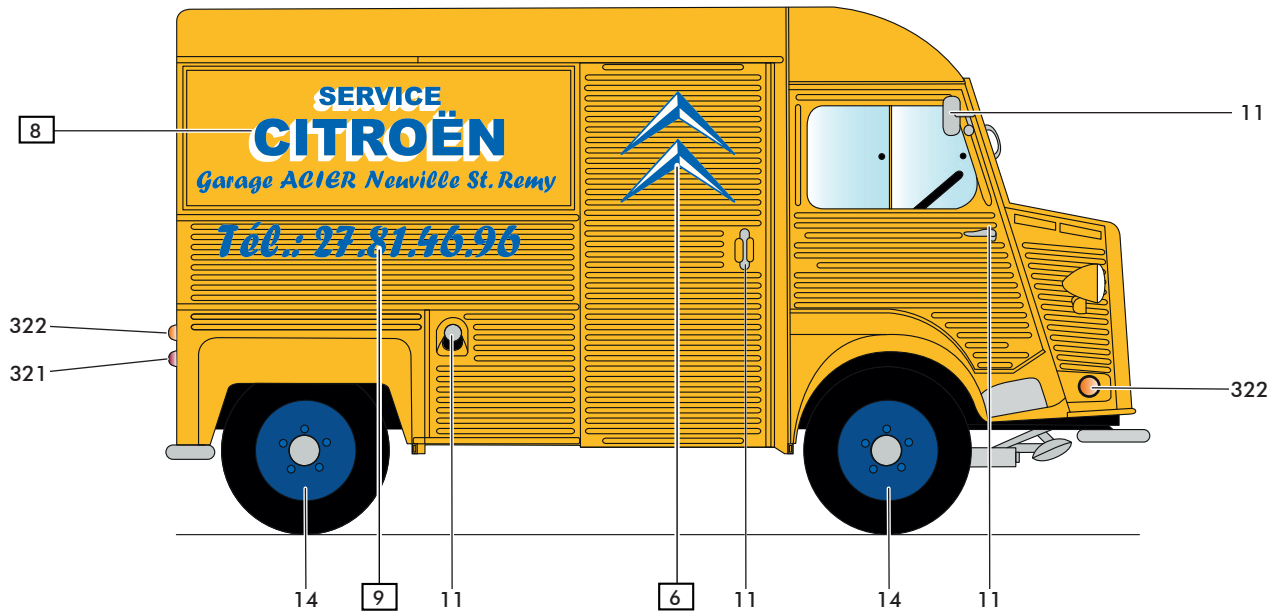
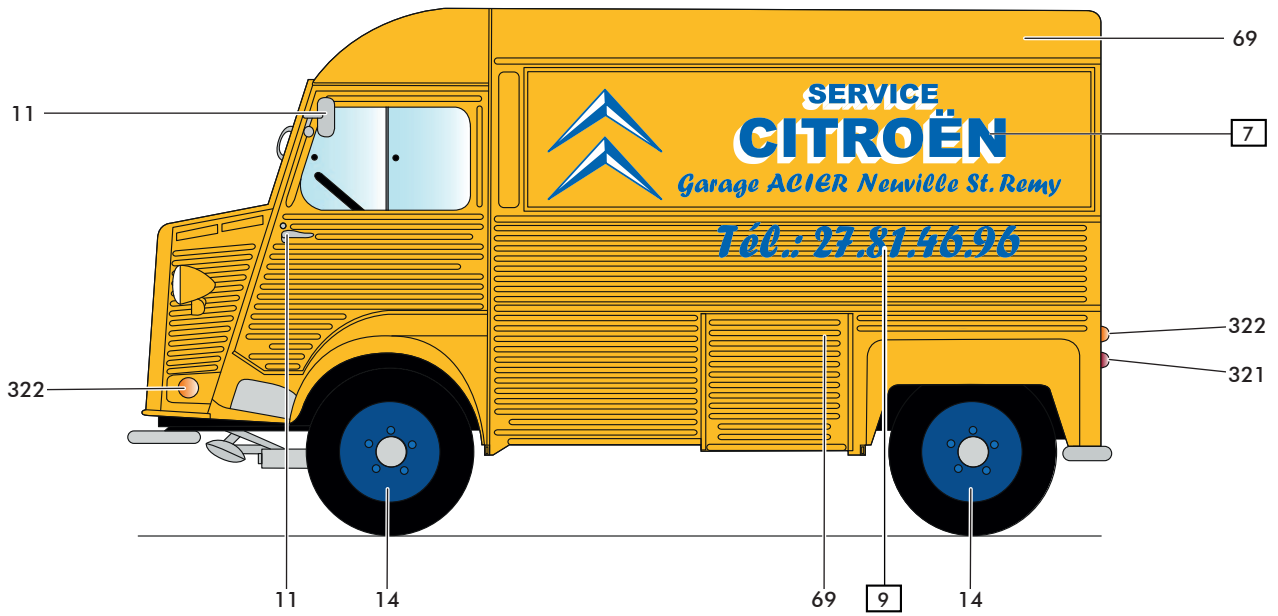

60

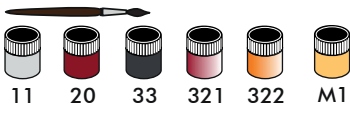

b • CITROËN HY, 1957

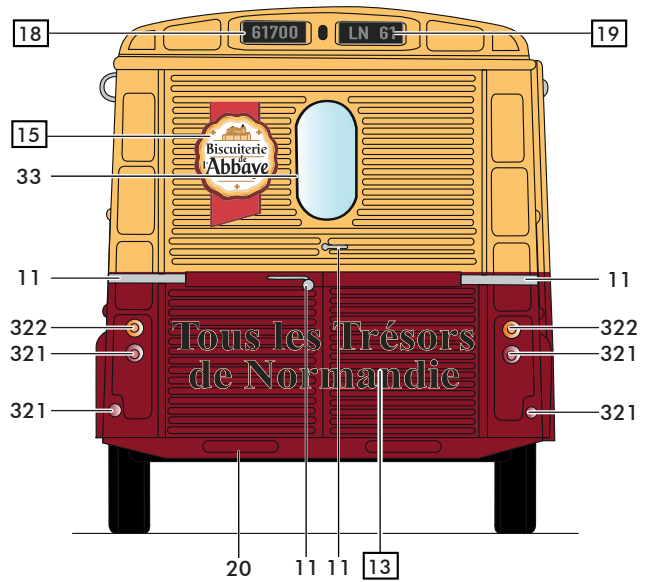
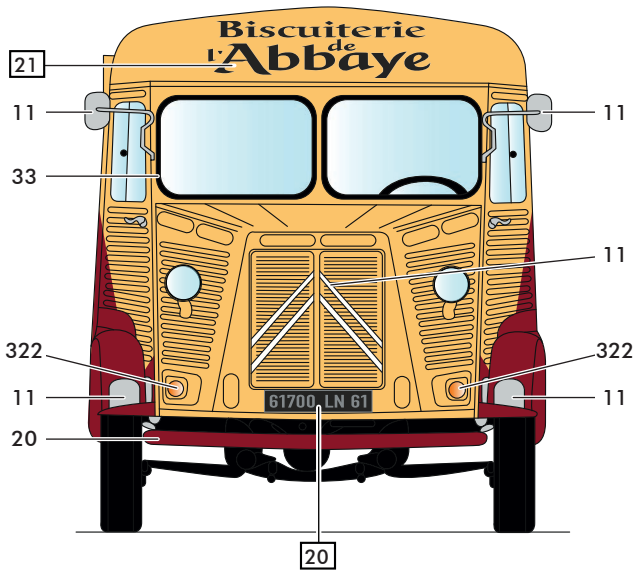
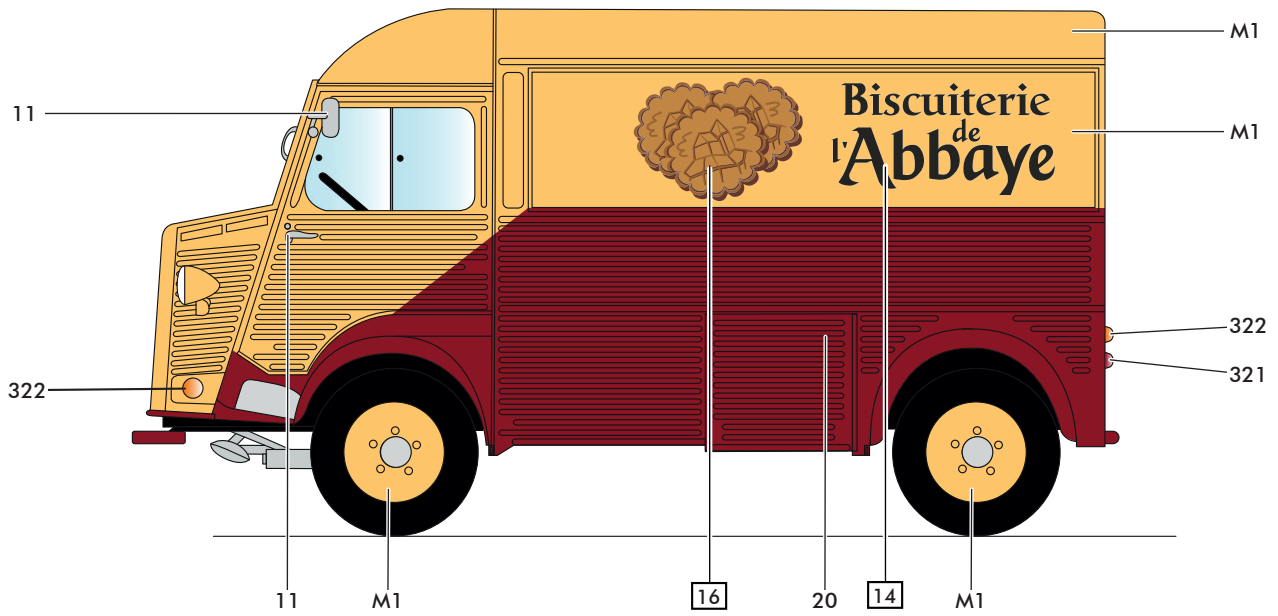

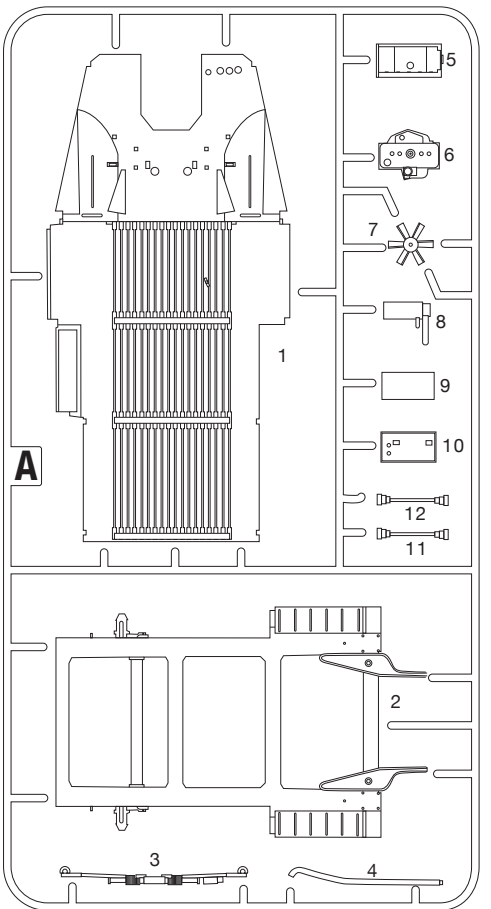
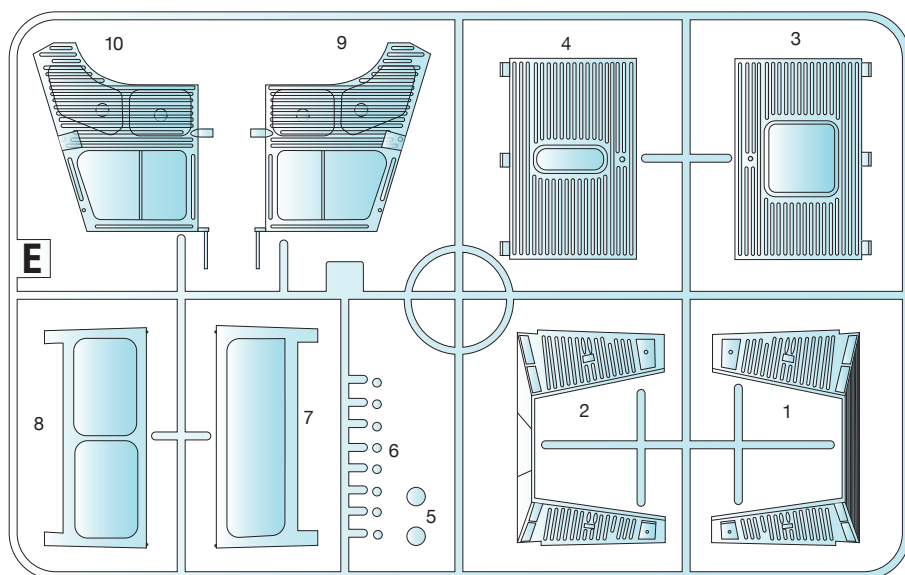
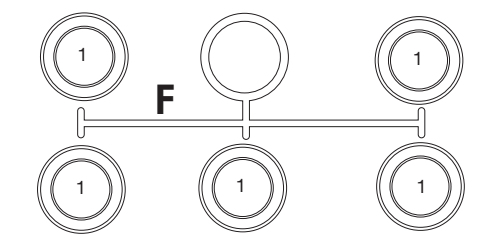
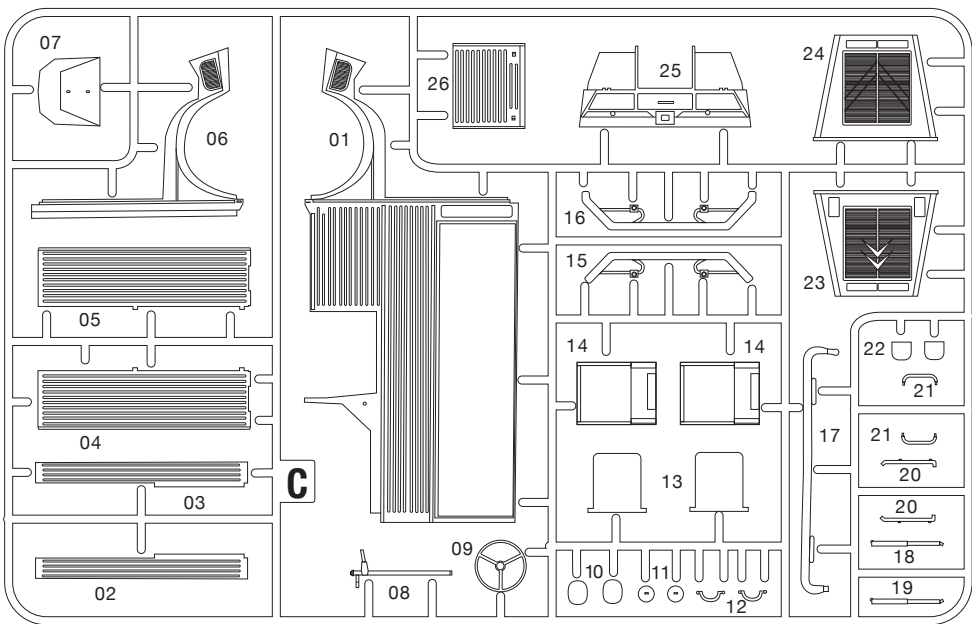
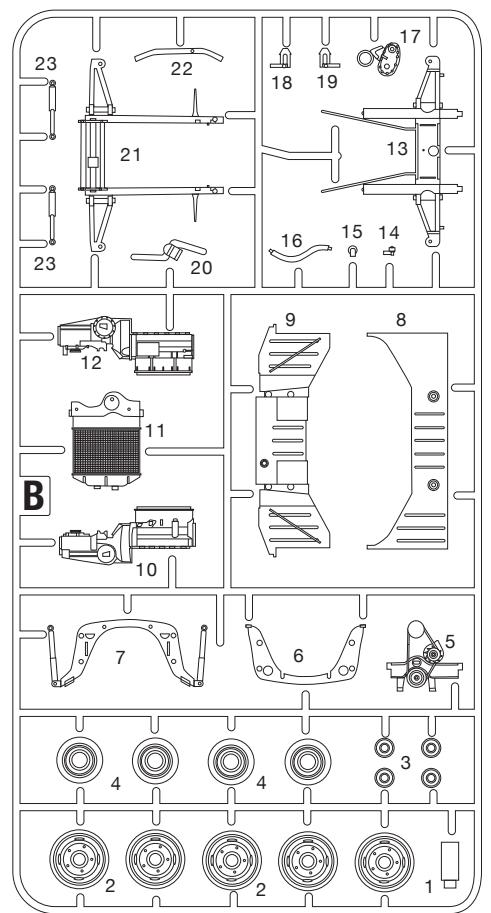
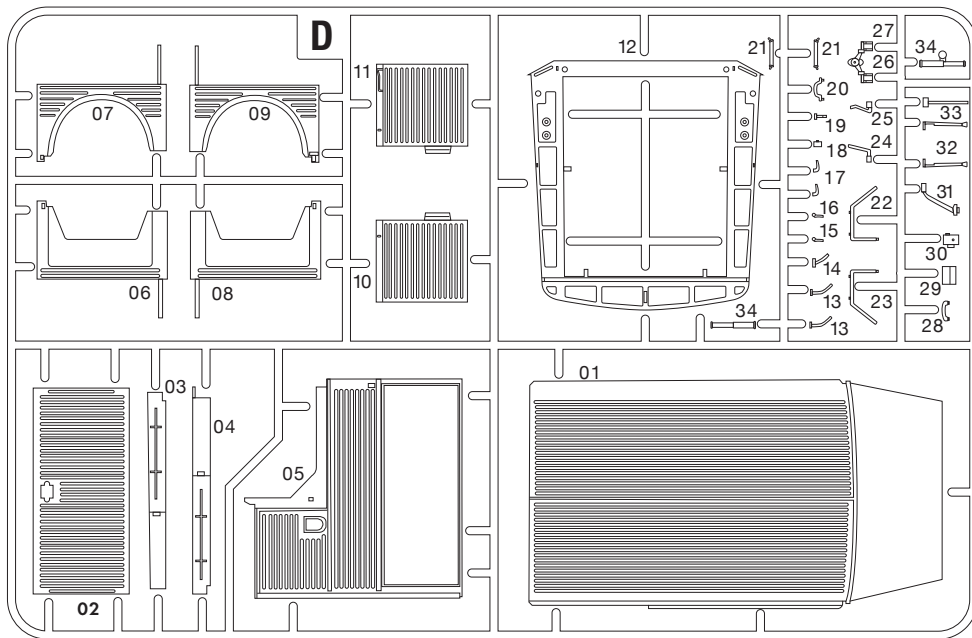

VISITEZ-NOUS SUR LES RÉSEAUX SOCIAUX

VISIT US ON SOCIAL MEDIA!
BESUCHEN SIE UNS AUF SOCIAL MEDIA!

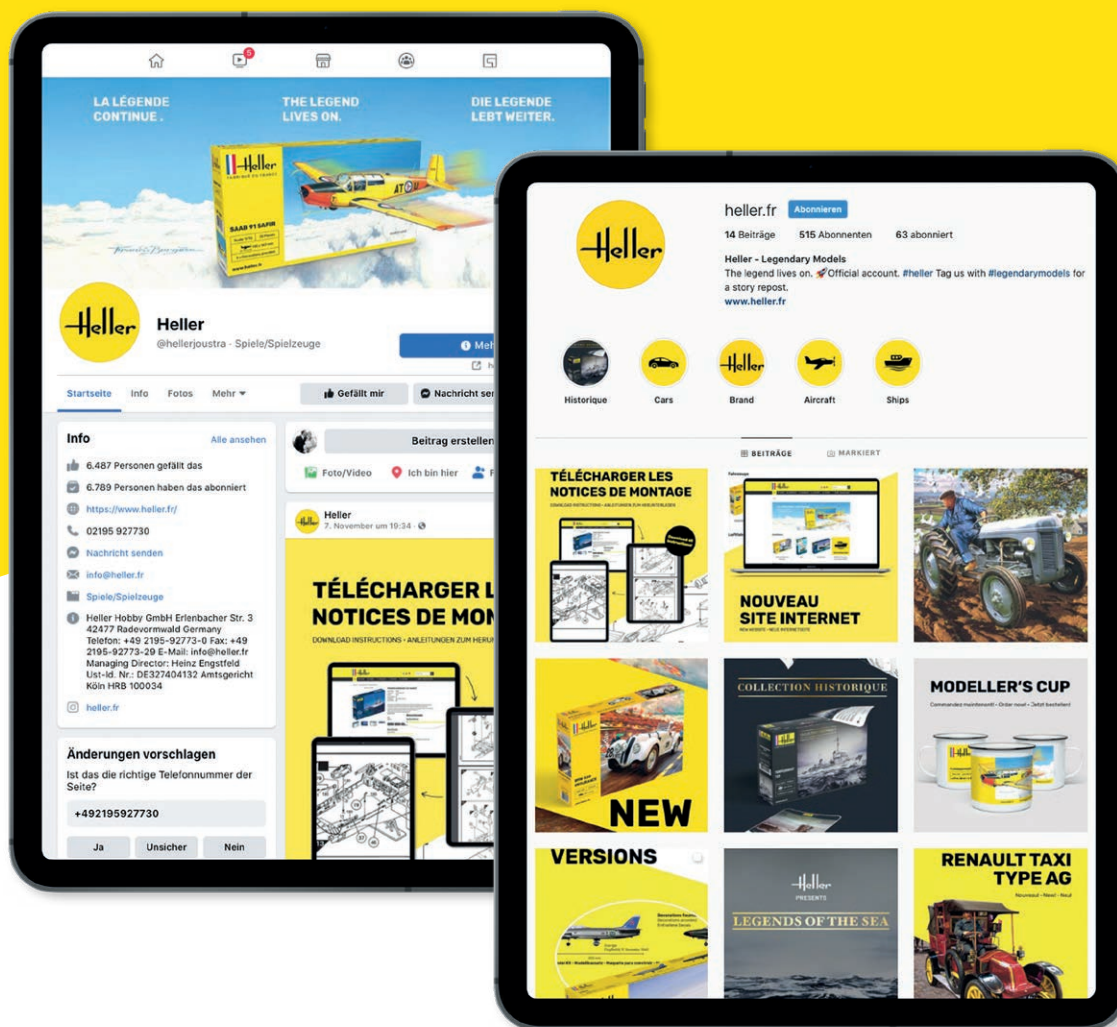

@instagram.com/heller.fr • facebook.com/heller.fr

VISITEZ-NOUS EN LIGNE !

VISIT US DIGITALLY!
BESUCHEN SIE UNS DIGITAL!

 www.heller.fr

 [instagram.com/heller.fr](https://www.instagram.com/heller.fr)

 [facebook.com/heller.fr](https://www.facebook.com/heller.fr)

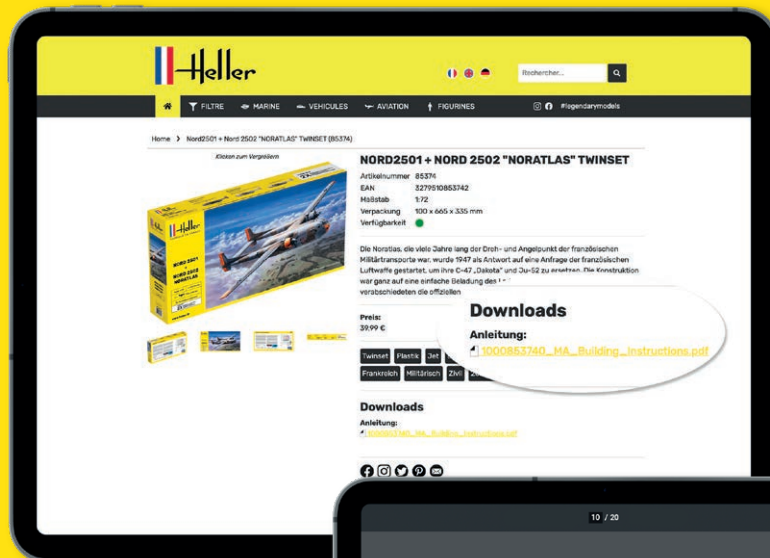

Choisissez l'article désiré et téléchargez la notice de montage.

Choose your desired article and download the instructions.

Wählen Sie den gewünschten Artikel und laden Sie die Anleitung herunter.

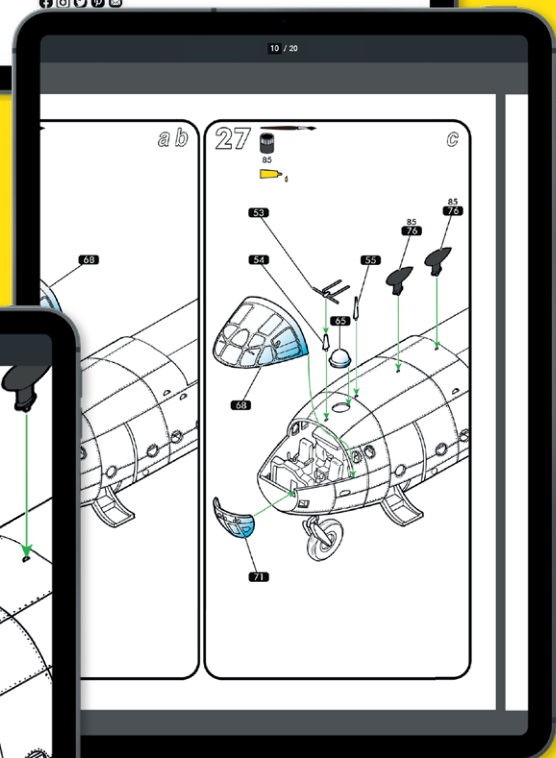

**Download all
instructions!**

**Grossissement des instructions pour
une vue détaillée.**

Enlarge the instructions for a more
detailed view.

Vergrößern Sie die Anleitung für eine
detailliertere Ansicht.

V-280821

Service consommateurs
Pour toute demande de SAV, connectez-vous
sur notre site www.heller.fr.

Customer Service
For after-sales service requests,
please contact us through our website
www.heller.fr.

Endverbraucherservice
Bitte besuchen Sie uns auf www.heller.fr
für alle Ersatzteilanfragen.

Heller Hobby GmbH

Erlenbacher Str. 3 • 42477 Radevormwald • GERMANY

 +49 (0) 2195-92773-0  info@heller.fr